



Marine Safety Center Technical Note

Date: November 10, 2003
SSIC: 16717/46 CFR 69/P009017
MTN: 01-99 CH-6

MARINE SAFETY CENTER TECHNICAL NOTE (MTN) NO. 01-99, CHANGE 6

Subj: TONNAGE TECHNICAL POLICY

1. Purpose: This Technical Note promulgates policy for use by authorized measurement organizations in interpreting and applying the provisions of Title 46, Code of Federal Regulations (CFR), Part 69, Measurement of Vessels. It replaces MTN 01-99 CH-5.
2. Discussion: To facilitate electronic access and printing, the material of this Technical Note is organized into five separate enclosures. Enclosures (1) through (4) provide specific interpretations of the tonnage regulations. These enclosures are based on a reprint in standard text of 46 CFR 69, Subparts B through E, with interpretive material in italicized format. Figures from the regulations appear in appropriate locations within the document, with the references to the figures deleted. Enclosure (5) consists of appendices which address policy grandfathering criteria and discuss changes from the previous version of this Technical Note. Side bars are used in the enclosures to highlight specific differences from the previous version of this document.
3. Applicability: Tonnage measurement in accordance with the interpretations of this Technical Note is required for vessels for which the application of a law of the United States depends on the vessel's tonnage. Refer to Navigation and Vessel Inspection Circular (NVIC) 11-93 for information regarding applicability of tonnage measurement systems to U.S. flag vessels.
4. Action: Authorized measurement organizations shall apply the technical interpretations of this Technical Note immediately. Any deviation from the interpretations of this Technical Note requires written approval from the Marine Safety Center. This Technical Note is available on the World Wide Web at <http://www.uscg.mil/hq/msc/mtns.htm>.

A handwritten signature in black ink that reads "Roy A. Nash".

R. A. NASH

- Encl: (1) Convention Measurement System (Subpart B) Interpretations
(2) Standard Measurement System (Subpart C) Interpretations
(3) Dual Measurement System (Subpart D) Interpretations
(4) Simplified Measurement Systems (Subpart E) Interpretations
(5) Appendices

CONVENTION MEASUREMENT SYSTEM



INTERPRETATIONS

TABLE OF CONTENTS

69.51 PURPOSE	3
69.53 DEFINITIONS	3
69.55 APPLICATION FOR MEASUREMENT	9
69.57 GROSS TONNAGE	9
69.59 ENCLOSED SPACES	10
69.61 EXCLUDED SPACES	11
(a) <i>GENERAL</i>	11
(b) <i>SPACE OPPOSITE END OPENINGS</i>	11
(c) <i>COVERED SPACE OPEN ON SIDES</i>	14
(d) <i>COVERED SPACE IN WAY OF SIDE OPENINGS</i>	14
(e) <i>SPACE BELOW UNCOVERED OPENING</i>	15
(f) <i>RECESSES</i>	15
(f') <i>SPACE OPEN TO THE SEA</i>	16
(g) <i>ADDITIONAL RESTRICTIONS ON EXCLUDED SPACES</i>	16
69.62 CARGO SPACES	16
(a) <i>SPACES INCLUDED IN V_c</i>	16
(b) <i>SPACES NOT INCLUDED IN V_c</i>	18
69.63 NET TONNAGE	18
69.65 CALCULATION OF VOLUMES	19
(a) <i>NAVAL ARCHITECTURAL PRACTICES</i>	19
(b) <i>HULL VOLUME</i>	19
(c) <i>DECK STRUCTURE VOLUME</i>	20
(d) <i>TERMINATION OF MEASUREMENTS</i>	23
(e) <i>MEASURING CARGO SPACES</i>	23
(f) <i>PRECISION OF MEASUREMENTS</i>	23
(g) <i>CALCULATION WORKSHEET</i>	23
(h) <i>SPACES IGNORED FROM VOLUME CALCULATIONS</i>	24
69.67 MARKING OF CARGO SPACES	24
69.69 ISSUANCE OF AN INTERNATIONAL TONNAGE CERTIFICATE (1969)	24
69.71 CHANGE OF NET TONNAGE	24
(a) <i>NET TONNAGE INCREASES</i>	24
(b) <i>VESSEL WITH DIFFERENT LOAD LINE ASSIGNMENTS</i>	25
(c) <i>NET TONNAGE DECREASES</i>	25
69.73 VARIANCE FROM THE PRESCRIBED METHOD OF MEASUREMENT	25
(a) <i>NOVEL VESSEL DETERMINATION</i>	25
(b) <i>SUBMITTAL OF DETERMINATION REQUESTS</i>	25
69.80 OPEN-TOP CONTAINERSHIPS	26
(a) <i>UPPER DECK DETERMINATION</i>	26
(b) <i>ENCLOSED SPACES</i>	26
(c) <i>TREATMENT OF SHELTER ABOVE CONTAINER STACKS</i>	26
69.81 OFFSHORE SUPPLY VESSELS (OSV'S)	27
69.85 REDUCED GROSS TONNAGE	27
(a) <i>VESSELS WITH QUALIFYING SEGREGATED BALLAST TANKS</i>	27
(b) <i>OPEN-TOP CONTAINERSHIPS</i>	27

CONVENTION MEASUREMENT SYSTEM (46 CFR 69 SUBPART B)

69.51 PURPOSE

This subpart prescribes the requirements for measuring a vessel in order to comply with the International Convention on Tonnage Measurement of Ships, 1969 (Convention), and 46 U.S.C. chapter 143.

69.53 DEFINITIONS

As used in this subpart -

AMIDSHIPS means the midpoint of the registered length, as “registered length” is defined in this section, where the forward terminal of that length coincides with the fore side of the stem.

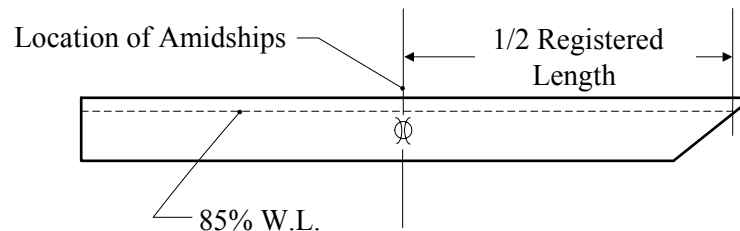

BOUNDARY BULKHEAD means the bulkhead or partition that separates an enclosed interior space from the surrounding weather. In general, the exterior bulkhead of a deck structure is the boundary bulkhead.

BULWARK means that part of a vessel's side above the upper deck that serves to protect the upper deck from exposure to the sea. Structures above the upper deck at the vessel's side that contain enclosed volume are not bulwarks, but rather are considered as superstructure spaces.

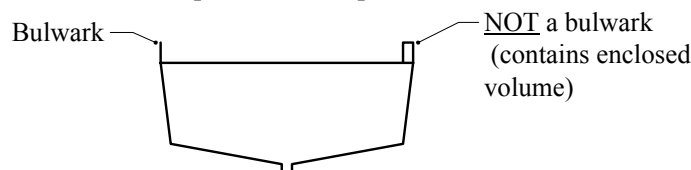

CARGO SPACE means an enclosed space appropriated for the transport of cargo which is to be discharged from the vessel. The term does not include a space which qualifies as an excluded space under § 69.61.

CEILING is defined in § 69.103.

CLEAN BALLAST TANK (CBT) means a dual use tank that can contain either cargo or water ballast and is fitted with an oil/water separation system. A dedicated clean ballast tank is a cargo tank used for water ballast only.

DECK CARGO is freight carried on the weather decks of a vessel for the sole purpose of its transport between two separate and distinct locations and which is off-loaded from the vessel in its original container (if applicable) without undergoing any processing or other use while onboard the vessel. For example, a JP-5 fuel tank being transported to an offshore platform and hoisted on board the platform with its original contents intact is considered deck cargo. If for the same tank, shipboard pumps were used to off-load the JP-5 to the platform, the tank would be considered temporary deck equipment, and not deck cargo. Note that the method of attachment does not determine whether an item is considered deck cargo. A bona fide shipping container can either be lashed or welded to the deck, provided it meets all the criteria for deck cargo as outlined above.

DECK STRUCTURE is any structure that is on or above the upper deck. Examples of deck structures are superstructures and deckhouses.

ENCLOSED SPACE is defined in § 69.59.

EXCLUDED SPACE is defined in § 69.61.

END OPENING is a covered enclosed space in the fore or aft end of a deck structure, which is bounded by less than two boundary bulkheads of the structure. (See the illustration under “Recess.”)

FLAT PLATE KEEL is the horizontal, centerline, bottom shell strake constituting the lower flange of the keel. The “top of the flat plate keel” refers to the top of this plate. In vessels that do not have a flat plate keel, the equivalent to the “top of the flat plate keel” is established as described in the definition for molded depth.

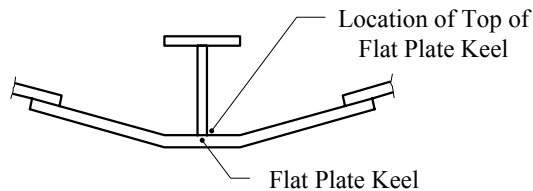

GROSS TONNAGE or GT means the tonnage determined under § 69.57. Gross tonnage is a measure of the overall size of a vessel.

LEAST MOLDED DEPTH (D_{lm}) means the vertical distance between: 1) the top of the flat plate keel (or equivalent) at the lowest point along its length; and 2) the horizontal line that is tangent to the underside of the upper deck at the vessel's side at the lowest point along the upper deck's length. For the purposes of this definition, the vessel is considered to be trimmed on a waterline parallel to the design waterline.

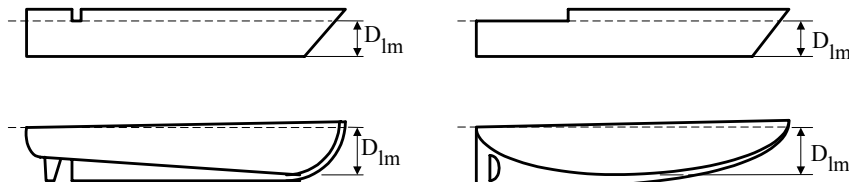

LINE OF THE UPPER DECK means a longitudinal line at the underside of the upper deck or, if that deck is stepped, the longitudinal line of the underside of the lowest portion of that deck parallel with the upper portions of that deck. Discontinuities in the upper deck that do not extend from side to side of the vessel, are one meter or less in length, or are outside the boundaries of “registered length,” are ignored when establishing the line of the upper deck.

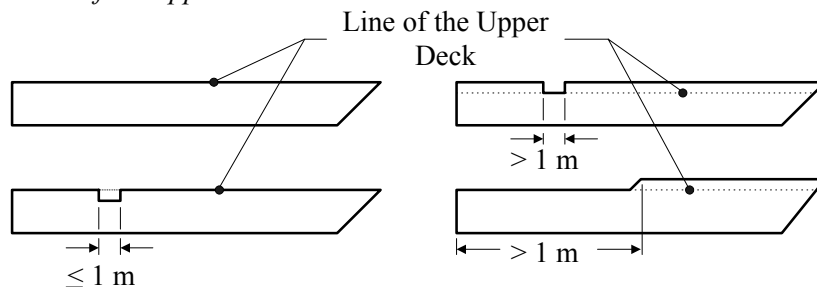

MOLDED DEPTH means the vertical distance amidships between the following points:

- (a) **Upper Terminus** From the line of the upper deck at the vessel's side or, if the vessel has rounded gunwales, from the intersection of the line of the upper deck extended to the molded line of the shell plating as though the gunwales were of angular design.

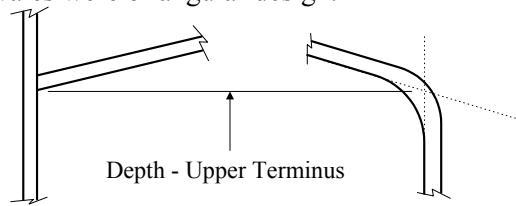

- (b) **Lower Terminus** To the top of the flat plate keel, or equivalent (i.e. to the lower edge of the keel rabbet if the vessel is of wood or composite structure, or to the point where the line of the flat of the bottom extended inward cuts the side of the keel if the vessel's lower part is hollow or has thick garboards).

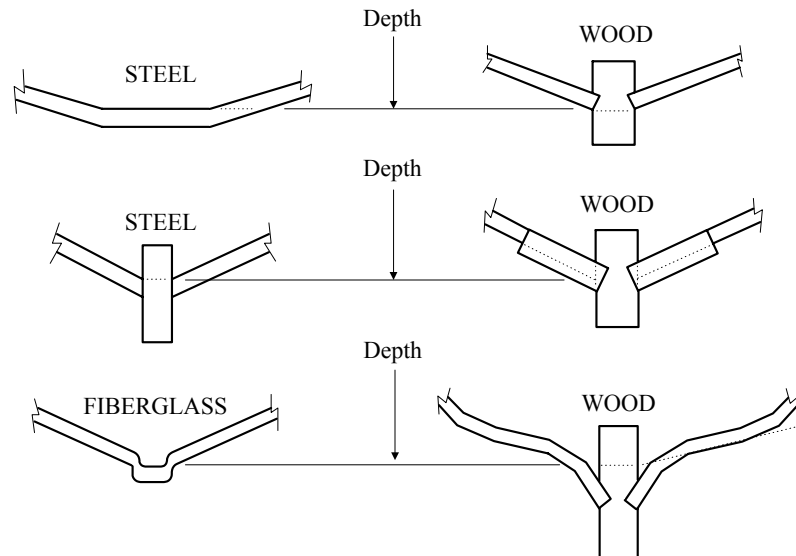

MOLDED DRAFT means -

- (a) **Vessels Assigned Load Line Under Parts 42, 44, 45 or 47** For vessels assigned a load line under parts 42, 44, 45, or 47 of this chapter, the draft corresponding to the Summer Load Line (other than a timber load line), measured from the lower terminus of the molded depth to the upper edge of the horizontal line through the load line (Plimsoll) mark.

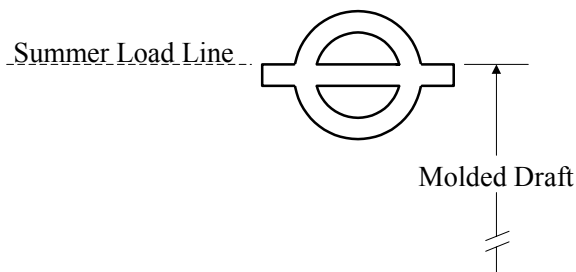

- (b) **Passenger Vessels Assigned Load Line Under Part 46** For passenger vessels assigned a load line under part 46 of this chapter, the draft corresponding to the deepest subdivision load line assigned;

- (c) **Other Vessels Assigned Load Line** For vessels to which parts 42, 44, 45, 46, or 47 of this chapter do not apply but which otherwise have been assigned a load line, the draft corresponding to the Summer Load Line so assigned;
- (d) **Vessels Otherwise Restricted in Draft** For vessels to which no load line has been assigned but the draft of which is restricted under any Coast Guard requirement, the maximum draft permitted under the restriction; and
- (e) **All Other Vessels** For other vessels, 75 percent of the molded depth.

NET TONNAGE or NT means tonnage determined under §69.63. *NT is a measure of the useful capacity of a vessel.*

OPEN-TOP CONTAINERSHIP is a vessel designed for the carriage of containers in holds which are not fitted with hatch covers. In section, it is “U” shaped, with a double bottom and high coamings on the upper deck to protect the cargo holds and without a complete deck above the molded draft. A complete deck is one which extends from stem to stern and side to side at all points of its length.

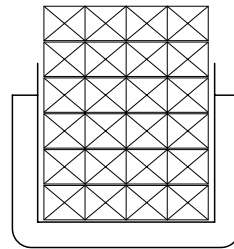

PASSENGER means a person on board a vessel other than -

- (a) The master, a member of the crew, or other person employed or engaged in any capacity in the business of the vessel; and
- (b) A child under one year of age.

RECESS is a covered enclosed space in a deck structure, which is bounded on at least two sides by the boundary bulkhead of the structure.

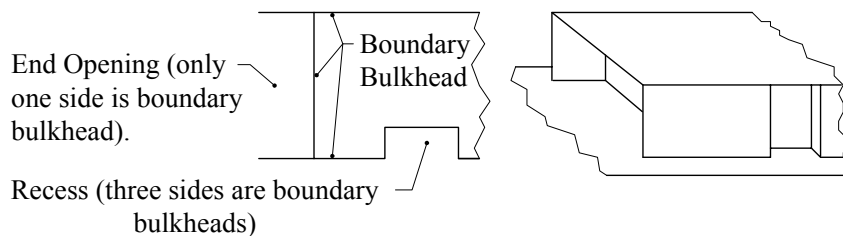

REGISTERED BREADTH means the maximum breadth of a vessel's hull measured **amidships** to the molded line of the frame in a vessel with a metal shell and to the outer surface of the hull in all other vessels.

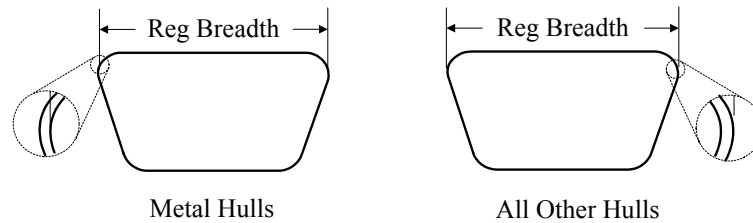

REGISTERED DEPTH means the molded depth as defined in this section. For vessels that are not monohulls (e.g. catamarans, trimarans, SWATH's), the registered depth shall be the molded depth of the deepest hull(s).

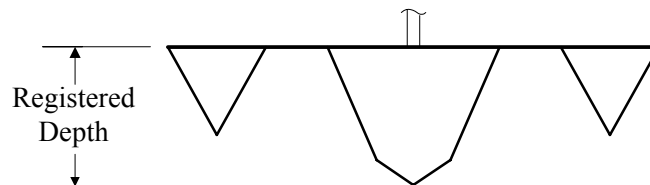

REGISTERED LENGTH means

- (a) **Monohull Vessels:** - For monohull vessels, either 1) 96 percent of the length from the fore side of the stem to the aftermost side of the stern on a waterline at 85 percent of the least molded depth measured from the top of the flat plate keel; or 2) the length from the fore side of the stem to the axis of the rudder stock on that waterline, whichever is greater.

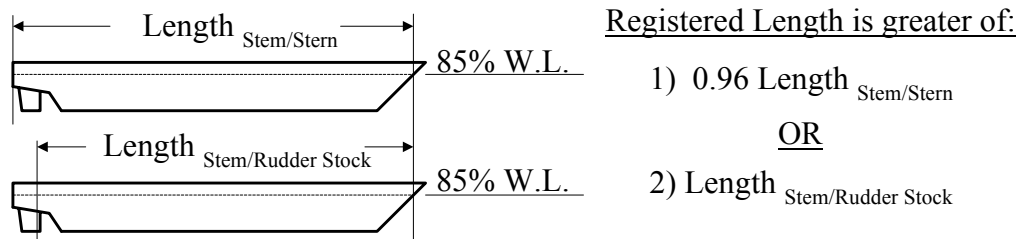

- (i) In vessels designed with a rake of keel, this length is measured on a waterline parallel to the design waterline. For such cases, the reference point used to establish the 85% waterline is taken at the point where the top of the flat plate keel, or equivalent, is lowest along the length of the vessel.

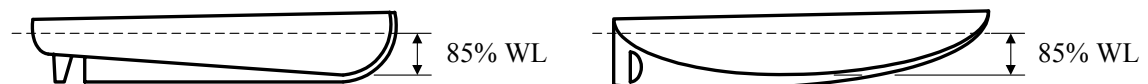

- (ii) In vessels fitted with an alternate steering device installed in place of the rudder (e.g. trainable propulsion unit, cycloidal propeller, etc.), the centerline of the axis of rotation of the device is considered equivalent to the axis of the rudder stock for purposes of establishing the length measurement. If more than one such device is installed, the axis of rotation of the aftermost device is considered equivalent to the axis of the rudder stock.

(iii) In all vessels, the stem and stern define the foremost and aftermost boundaries, respectively, of the buoyant hull envelope. Any attachment to the hull, such as a swim platform that is not part of the hull and does not contain buoyant volume, is ignored from measurements taken to the stem/stern.

(b) **Multihull Vessels** - For multihull vessels (such as SWATH's, catamarans, trimarans, semi-sub MODU's, etc.), the registered length as defined under the simplified measurement system (§ 69.203).

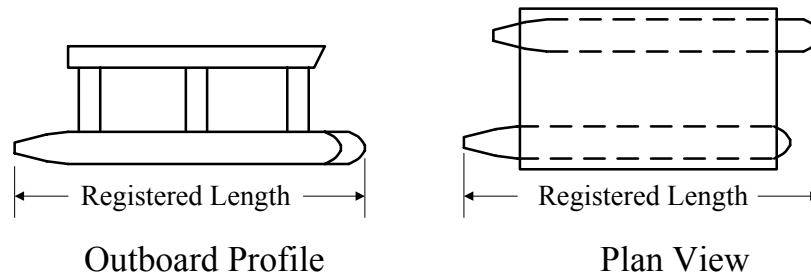

SEGREGATED BALLAST TANK (SBT) means a tank exclusively used for the carriage of segregated water ballast, and which is completely separated from the cargo oil and fuel oil systems.

SPARRING is wooden protection of vertical surfaces in way of frames in cargo holds, also called cargo battens. Sparring is also used in spaces designed for bulk stowage and refrigerated stores in order to allow for ventilation.

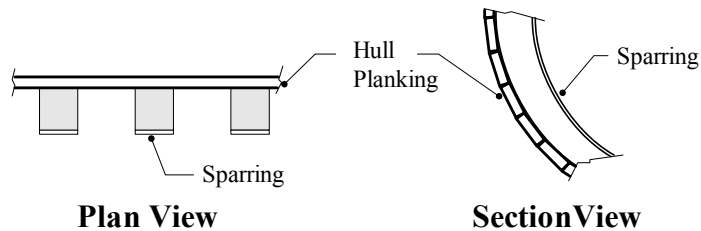

TEMPORARY DECK EQUIPMENT means any item of a semi-permanent nature which is located on the weather deck of a vessel and which cannot be considered as deck cargo. Examples of temporary deck equipment include processing tanks, seismic trailers, and portable machinery that is operated on the ship.

UPPER DECK means the uppermost complete deck exposed to weather and sea, which has permanent means of weathertight closing of all openings in the weather part of the deck, and below which all openings in the sides of the vessel are fitted with permanent means of watertight closing.

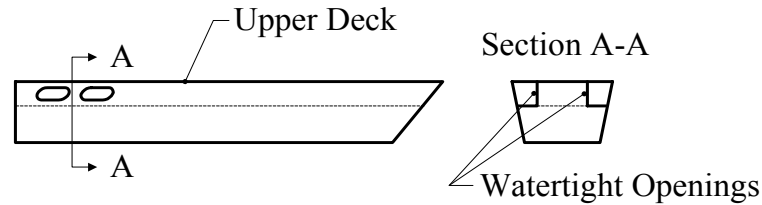

For a vessel having openings in the side of the vessel below the uppermost continuous (or “complete”) deck, which are not closed but limited inboard by weathertight versus watertight bulkheads and decks, the deck below such openings should be considered the upper deck.

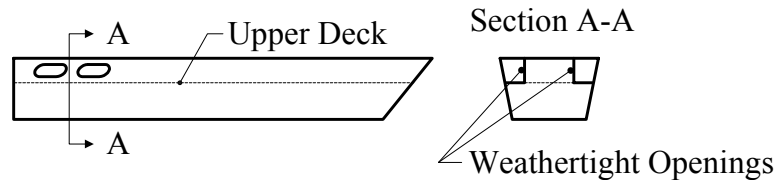

WEATHERTIGHT means secure against penetration of water into the vessel in any sea condition, *including intermittent immersion such as wave action and spray*.

WATERTIGHT means capable of preventing the passage of water through the structure or closure in any direction under a head of water for which the surrounding structure is designed.

69.55 APPLICATION FOR MEASUREMENT

Applications for measurement under this subpart must include the following information and plans:

- (a) Type of vessel
- (b) Vessel’s name and official number (if assigned).
- (c) Builder’s name and the vessel hull number assigned by *the* builder.
- (d) Place and year built.
- (e) Date keel was laid.
- (f) Overall length, breadth, and depth of vessel.
- (g) Lines plan.
- (h) Booklet of offsets at stations.
- (i) Capacity plans for tanks and cargo compartments.
- (j) Hydrostatic curves.
- (k) Construction plans showing measurements and scantlings of deck structures, hatches, appendages, recesses, and other enclosed spaces.
- (l) Arrangement plans.

69.57 GROSS TONNAGE

Gross Tonnage (GT) is determined by the following formula:

$$GT = K_1 V$$

in which:

$$V = \text{total volume of all enclosed spaces in cubic meters; and}$$

$$K_1 = 0.2 + 0.02 \log_{10} V$$

The final figures determined by the above formula and stated on the appropriate tonnage certificate(s) should be given in rounded down figures without decimals.

69.59 ENCLOSED SPACES

Enclosed space means a space which is bounded by the vessel's hull, by fixed or portable partitions or bulkheads, or by decks or coverings other than permanent or movable awnings. *In general, a space is considered an enclosed space if it is:*

- (a) covered from above (excepting awnings) and below; or*

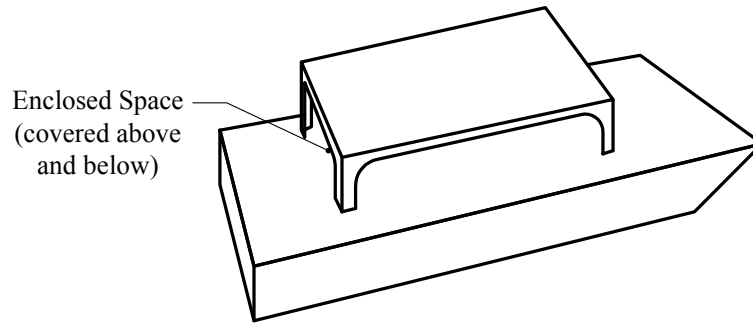

- (b) covered from above or below and enclosed on three or more sides by partitions or bulkheads that exceed 5 feet (1.5 meters) in height as measured from the lowest point of the enclosed space (refer to § 69.81 for exception for offshore supply vessels (OSV's)).*

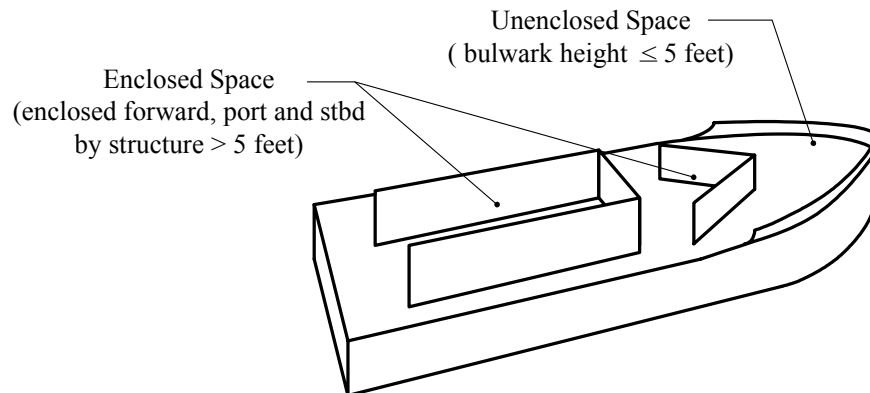

In the situation where only a portion of a bulkhead or partition exceeds 5 feet (1.5 meters) in height, the entire inboard space in way of that portion of the structure from the deck to the top of the structure must be included in the total volume of all enclosed spaces (V).

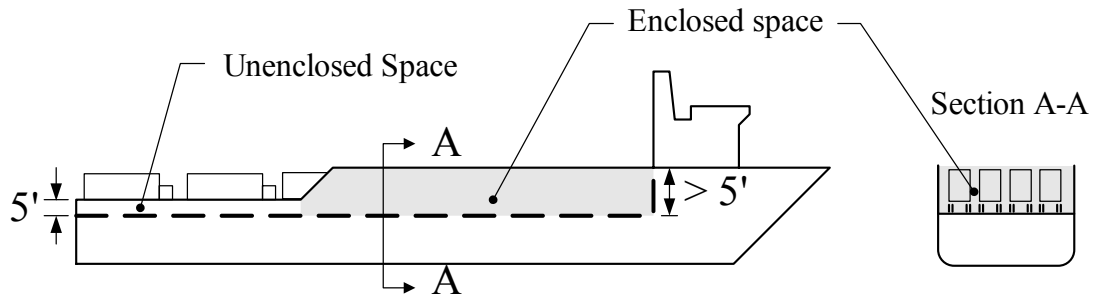

No break (*e.g. step*) in a deck, nor any opening in the vessel's hull, in a deck or in a covering of a space, or in the partitions or bulkheads of a space, nor the absence of a partition or bulkhead precludes the space from being included in the *total volume of all enclosed spaces (V)*. The following miscellaneous spaces are considered enclosed spaces:

- (a) Temporary deck equipment which has enclosed volume (*e.g., processing tanks, seismic trailers, housed portable machinery, etc.*).
- (b) Spaces below cargo hatches of multipurpose vessels which have the facility to trade with cargo hatches open or closed, regardless of the hatch position when the vessel is measured.
- (c) Appendages which have enclosed volume (except for movable items such as rudders which can be considered as unenclosed machinery and thereby ignored from measurement).
- (d) Uncovered spaces bounded on three sides by bulwarks - or portions of bulwarks - that exceed 5 feet (1.5 meters) in height.

69.61 EXCLUDED SPACES

(a) GENERAL

Excluded space means an enclosed space which is excluded from the *total volume of all enclosed spaces (V)* in calculating gross tonnage. Except as under paragraph (g) of this section, this section lists the excluded spaces.

(b) SPACE OPPOSITE END OPENINGS

A space that is within a *deck* structure and that is opposite an end opening extending from deck to deck (except for a curtain plate of a height not exceeding by more than one inch the depth of the adjoining deck beams) and having a breadth equal to or greater than 90 percent of the breadth of the *deck structure at deck level* at the line of the opening is an excluded space, subject to the following:

- (1) **Unrestricted End Opening** Only the space between the actual end opening and a line drawn parallel to the line or *the* face of the opening at a distance from the opening equal to one-half of the breadth of the *deck structure at deck level* at the line of the opening is excluded.

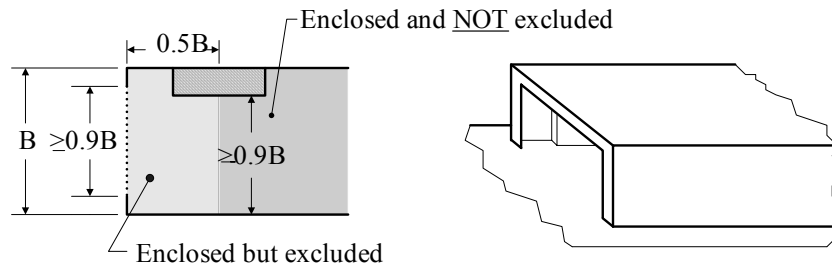

- (2) **Restricted End Opening** If, because of any arrangement (except convergence of the outside plating as shown *below*), the breadth of the space is less than 90 percent of the breadth of the *deck structure at deck level*, only the space between the line of the opening and a parallel line drawn through the point where the athwartship breadth of the space is equal to 90 percent or less of the breadth of the *deck structure at deck level* is excluded.

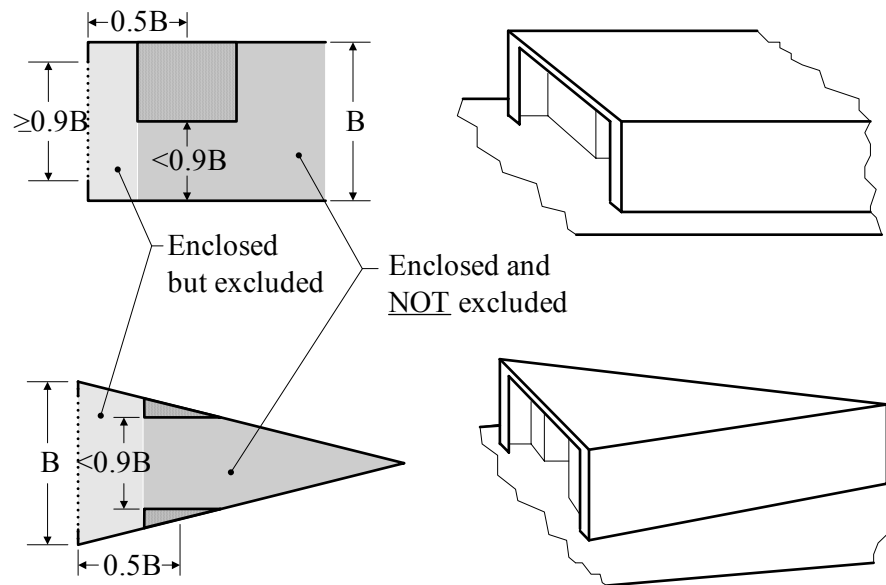

For the situation where the breadth of the space decreases solely due to the convergence of the outside plating, the 90% restriction does not apply.

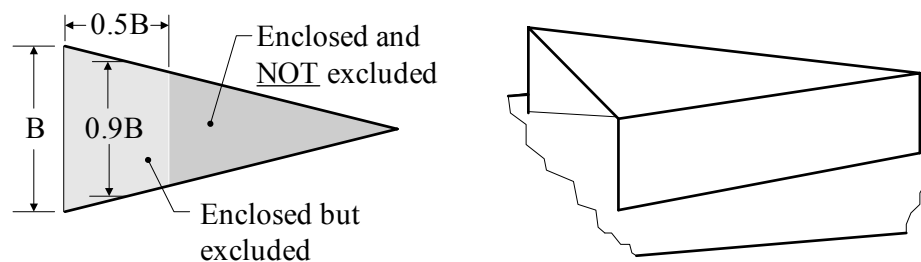

- (3) **Excluded Spaces Separated by Open Space** When any two spaces, either of which is excluded under paragraphs (b)(1) or (b)(2) of this section, are separated by an area that is completely open except for bulwarks or open rails, these two spaces must not be excluded if the separation between the two spaces is less than the least half breadth of the deck in way of the separation.

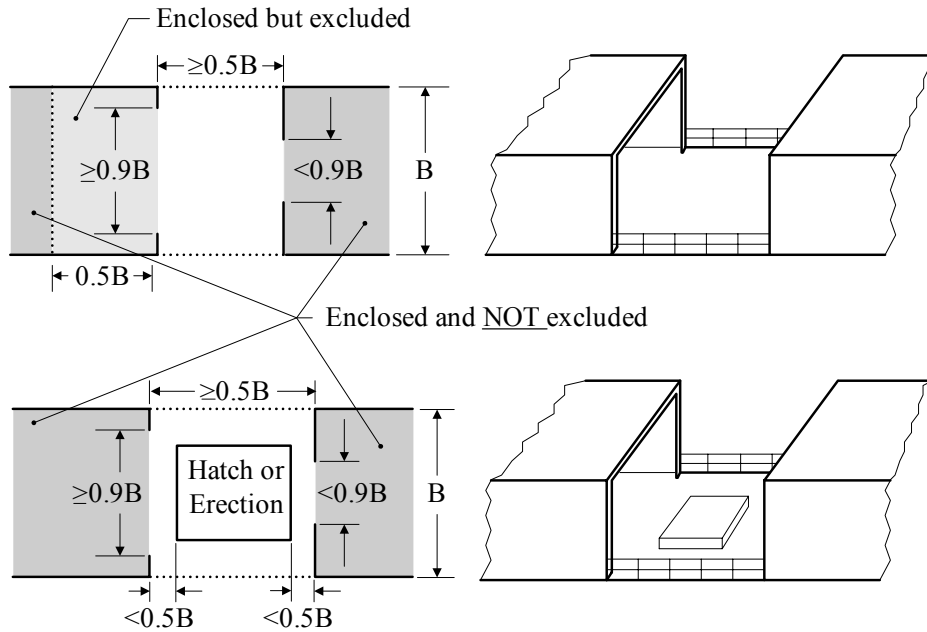

- (4) **Determining Breadth of Deck (B)** When the deck at the line of an opening has rounded gunwales, the breadth of the deck is the distance between the tangent points indicated below.

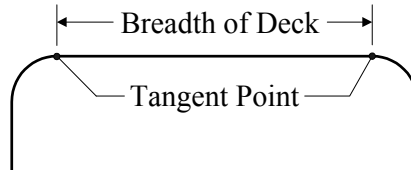

(c) COVERED SPACE OPEN ON SIDES

A space that is open to the weather and that is under an overhead deck covering with no connection on the space's exposed sides between the covering and the deck other than the stanchions necessary for the covering's support is an excluded space. An open rail or bulwark fitted at the vessel's side does not disqualify the space from being an excluded space if the height between the top rail or bulwark and the overhead structure or curtain plate (if fitted) is not less than 2.5 feet or one-third of the height of the space, whichever is greater.

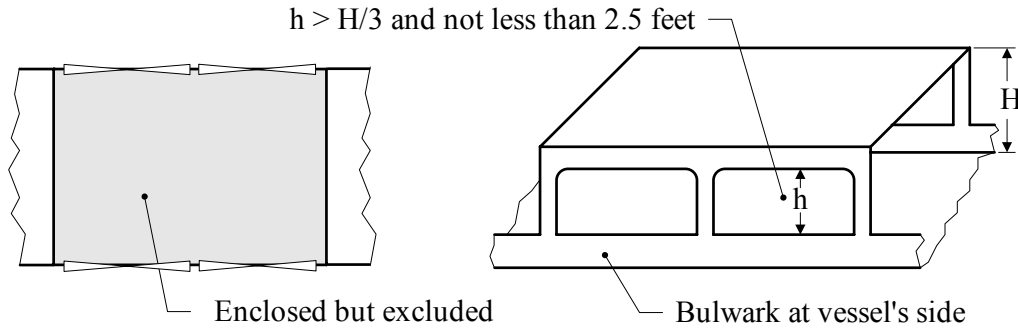

These same requirements apply to the situation where an interior structure partially supports the overhead deck covering.

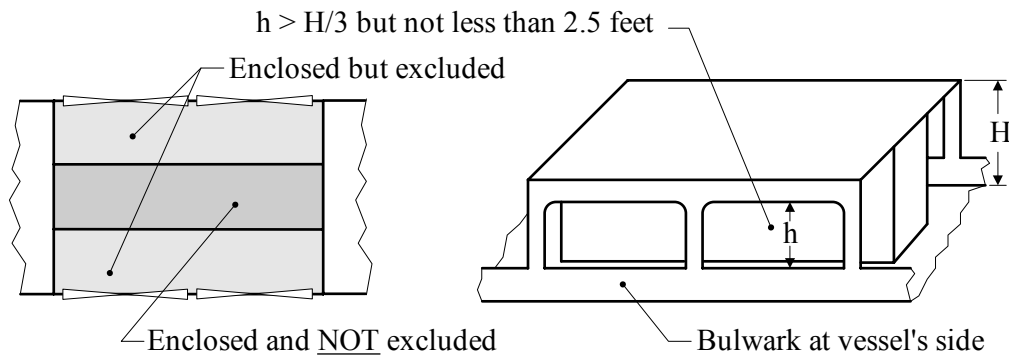

(d) COVERED SPACE IN WAY OF SIDE OPENINGS

A space in a side-to-side deck structure directly in way of opposite side openings not less than 2.5 feet in height or one-third of the height of the structure, whichever is greater, is an excluded space.

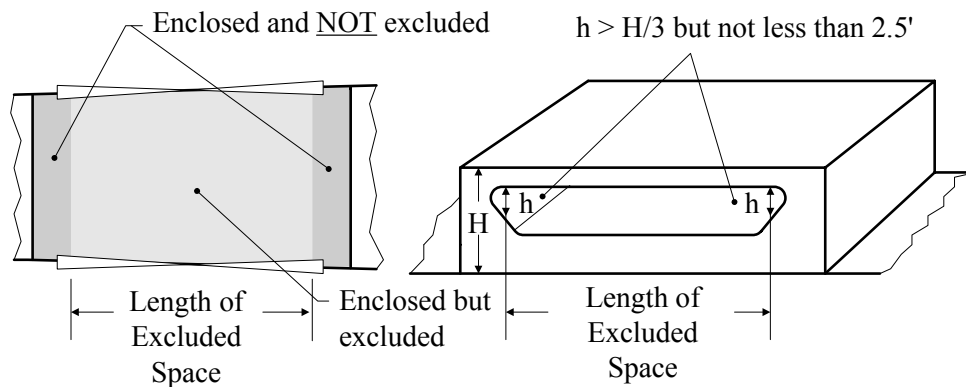

If the opening is only on one side of the *deck* structure, the space to be excluded is limited inboard from the opening to a maximum of one-half the breadth of the deck in way of the opening.

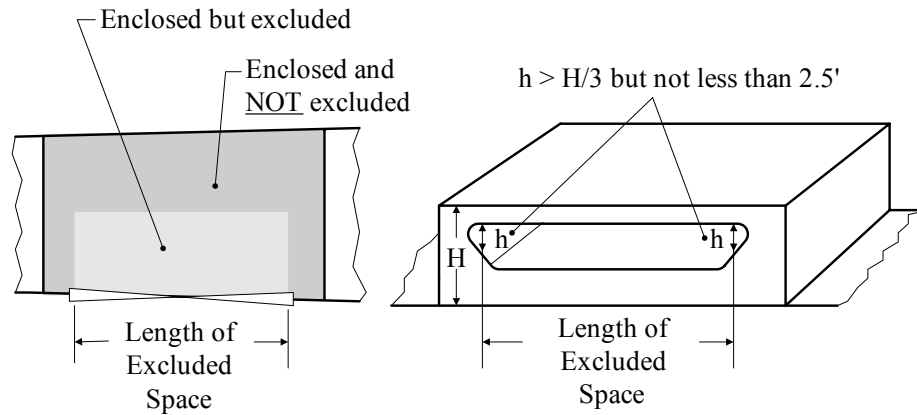

(e) SPACE BELOW UNCOVERED OPENING

A space in a *deck* structure immediately below an uncovered opening in the deck overhead or that is otherwise open from above is an excluded space, if the opening is exposed to the weather and the space to be excluded is limited to the area of the opening.

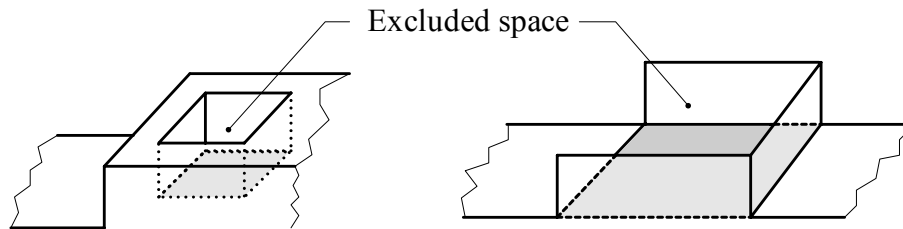

(f) RECESSES

A recess in a *deck* structure which is exposed to the weather and which has an opening that extends from deck to deck without a means of closing is an excluded space, if the interior width of the space is not greater than the width of the opening and extension of the space into the structure is not greater than twice the width of the opening. *In order to be considered to extend from deck to deck, the depth of any curtain plate at the entrance of the recess cannot exceed by more than one inch the depth of the adjoining deck beams.*

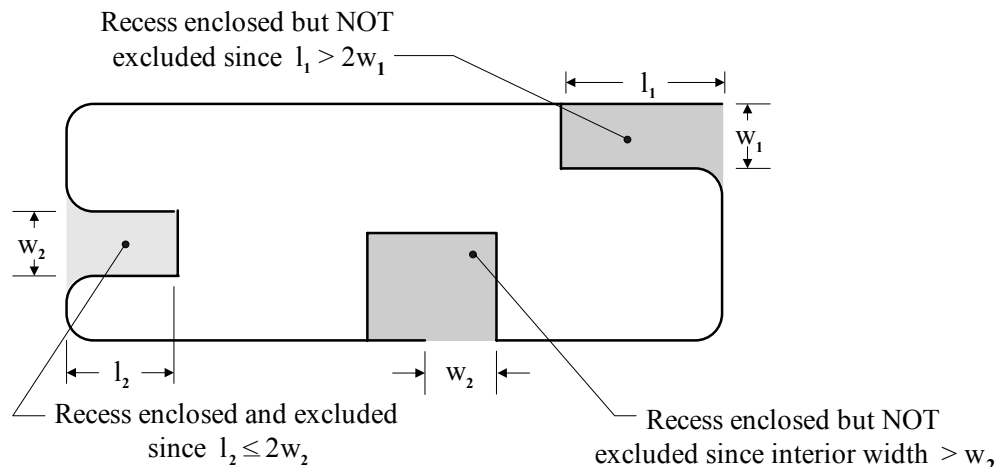

(f') SPACE OPEN TO THE SEA

An enclosed space that is open to the sea is an excluded space. For a space to be considered open to the sea, the space must be located on the seaward side of the vessel's buoyant hull envelope (i.e., below the upper deck) and, when the vessel is hypothetically immersed to the upper deck, the space must fill with water. In addition, a space can be considered open to the sea only if the space can fill with water without any detrimental effect on the operation of the vessel.

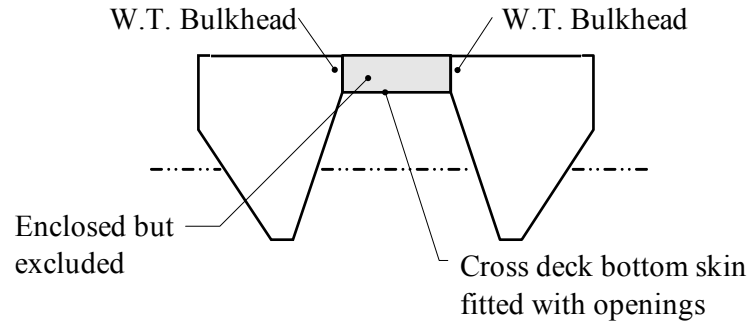

Hawse pipes, sea valve recesses, thruster tunnels, stern chutes in fishing vessels, and dredging wells in dredgers are generally treated as spaces open to the sea. Accordingly, they may be eligible for treatment as excluded spaces.

(g) ADDITIONAL RESTRICTIONS ON EXCLUDED SPACES

Any space described in paragraphs (b) through (f') of this section which fulfills at least one of the following conditions is **not** an excluded space (i.e. cannot be excluded from the total volume of all enclosed spaces (V)):

- (1) **Space Fitted With Means of Securing Cargo or Stores** The space is fitted with shelves or other means designed for securing cargo or stores. This **includes** stanchions, fences and railings for restraining livestock. This **does not include** passenger benches/seats and shelves/racks for safety equipment, such as fire extinguishers, life jackets, and life rafts.
- (2) **Opening Fitted With Closure Means** The opening that would otherwise permit the space to be excluded space is fitted with a means of closure.
- (3) **Opening Can Otherwise be Closed** Other features of the space make it possible for the space to be closed.

69.62 CARGO SPACES

The total volume of all cargo spaces (V_c) is used to calculate net tonnage. Information on specific cargo related spaces and how they are treated is provided below:

(a) SPACES INCLUDED IN V_c

Cargo related spaces that are included in the total volume of cargo spaces (V_c):

- (1) **Clean Ballast Tanks** Clean ballast tanks in oil tankers when the vessel is fitted with a crude oil washing system which would permit dual purpose cargo/clean ballast tank use of the tanks.
- (2) **Slop Tanks** Slop tanks for cargo residue.

- (3) **Fish Processing Spaces** *In fishing vessels, fish processing spaces for fishmeal, liver oil and canning, tanks for re-cooling fish, wet fish bunkers, and stores for salt, spices, oil and tare.*
- (4) **Refrigeration Machinery Spaces** *Refrigerating machinery spaces associated with refrigerating cargoes, situated within the boundaries of the cargo spaces.*
- (5) **Dual Purpose Spaces** *Dual purpose spaces which carry cargo at any time, such as tanks used for both ballast and cargo.*
- (6) **Automobile Spaces** *Spaces allocated to passenger automobiles.*
- (7) **Passenger Service Spaces** *Mail rooms, baggage compartments separate from passenger accommodations, and bonded stores for passengers.*
- (8) **Space in Pontoon Hatch Covers** *Weathertight steel pontoon hatch covers on hatchway coamings, if such covers are open on the underside.*
- (9) **Dock Deck Areas** *The space within the dock of a dockship.*

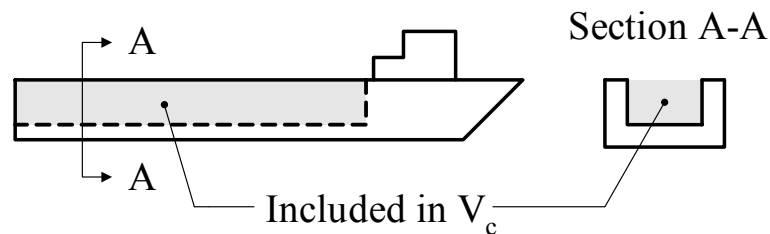

- (10) **Cargo Spaces Temporarily Open to the Sea** *Cargo spaces within the hulls of vessels such as split-hull barges and dredgers that are open to sea when cargo is discharged.*

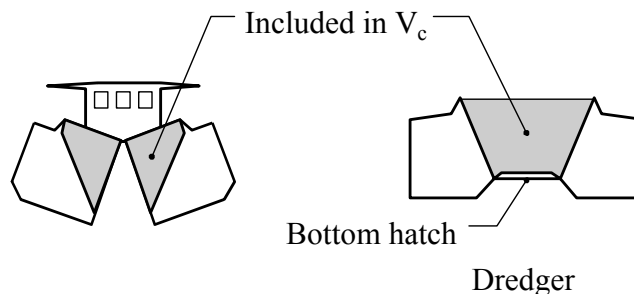

- (11) **Hoppers on Deck Barges** Cargo spaces within a hopper or similar structure on deck barges. Note that under the provisions of Section 69.59, these spaces should be ignored from volume calculations if the height of the hopper above the deck does not exceed 5 feet (1.5 meters).

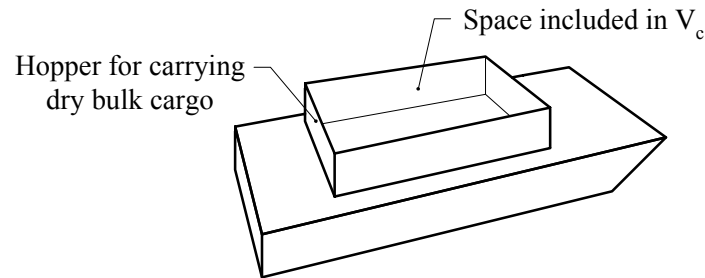

(b) **SPACES NOT INCLUDED IN V_c**

Cargo related spaces that are not included in the total volume of cargo spaces V_c:

(1) **Segregated Ballast Tanks**

(2) **Dedicated Clean Ballast Tanks**

(3) **Converted Tanks on Combination Carriers** On combination carriers, dual purpose oil/ballast tanks that have been converted to ballast tanks provided the ballast tanks are: 1) permanently disconnected from the oil cargo system; 2) connected to an independent ballast system; and 3) solely allocated to carry ballast.

(4) **Provision Rooms/Bonded Stores** Provision rooms for crew or passengers and bonded stores for crew.

(5) **Fishing Gear** In fishing vessels, spaces used exclusively for storing fishing gear.

(6) **Passenger Accommodations** Spaces utilized for passenger accommodations.

(7) **Deck Cargo** Any deck cargo carried aboard the vessel.

69.63 NET TONNAGE

Net tonnage (NT) is determined by the formula:

$$NT = K_2 V_c (4d/3D)^2 + K_3 (N_1 + N_2/10)$$

in which,

V_c = total volume of cargo spaces (excluding passenger spaces) in cubic meters

K₂ = 0.2 + 0.02 log₁₀ V_c

K₃ = 1.25 [(GT + 10,000) / 10,000]

D = molded depth amidships in meters, as “molded Depth” is defined in § 69.53

d = molded draft amidships in meters, as “molded draft” is defined in § 69.53

N₁ = number of passengers in cabins with not more than eight berths, as “passenger” is defined in § 69.53

N₂ = number of other passengers, as “passenger” is defined in § 69.53

GT = gross tonnage as determined under § 69.57

and with the following restrictions:

N_1 plus N_2 must equal the total number of passengers the vessel is permitted to carry as indicated on the Ship's Passenger Certificate (*i.e.*, SOLAS Certificate or similar document). If these documents have not been issued (or will not be issued), a written statement from the vessel owner/agent attesting to the number of passengers can be used instead, provided the owner provides written agreement to notify the measurement organization if the number of passengers changes. If N_1 plus N_2 is less than 13, both N_1 and N_2 are zero.

$(4d/3D)^2$ must not be greater than unity.

$K_2 V_c (4d/3D)^2$ must not be less than 0.25 GT

NT must not be less than 0.30 GT.

The final figures determined by the above formula and stated on the appropriate tonnage certificate(s) should be given in rounded down figures without decimals.

69.65 CALCULATION OF VOLUMES

(a) NAVAL ARCHITECTURAL PRACTICES

Volumes V and V_c used in calculating gross and net tonnages, respectively, must be measured and calculated according to accepted naval architectural practices for the spaces concerned.

(b) HULL VOLUME

The volume of the hull below the upper deck is determined as follows. *As an alternative to §69.65(b)(1)-(4) below, any method that is accepted naval architectural practice may be used to determine the volume of the hull below the upper deck.*

- (1) **Existing Stations** If the number and location of sections originally used in making other calculations which relate to the form of the vessel (such as displacement volumes and center of buoyancy) are reasonably available, Simpson's first rule, or any other integration method that is acceptable naval architectural practice, may be applied using those sections.
- (2) **Moorsoom Method** If the number and location of stations originally used are not reasonably available or do not exist and the hull is of conventional design with faired lines, Simpson's first rule may be applied using a number and location of stations not less than those indicated in §69.109(g)(1). *Faired lines in this context means that the hull does not have chines, longitudinal discontinuities, or any other knuckles or similar discontinuities that would render use of Simpson's first rule inappropriate.*
- (3) **Standard Geometric Shape** If the hull is of standard geometric shape, a simple geometric formula that yields a more accurate volume may be used.
- (4) **Hull Not Fair** If the lines of the hull are not fair, the volume may be measured by using a combination of methods under this section, or any other method, provided that the volume so measured is calculated according to acceptable naval architectural practices.

(5) **Linear Appendages Less Than 1 m² in Area** The volumes of linear appendages of complex shape (e.g., hollow skegs and hollow bilge keels) can be calculated by multiplying an average (approximate) sectional area by an average (approximate) length, provided the average sectional area of the appendage does not exceed one square meter.

(c) **DECK STRUCTURE VOLUME**

The volume of structures above the upper deck may be measured by applying the superstructure provisions in §69.113 (if applicable) or by any accepted method or combinations of methods. In general, the same longitudinal and vertical integration schemes that are accepted naval architecture practices used in the calculation of hull volumes may be used for deriving volumes of deck structures.

(1) **Volume Calculation Methods** Structures may be modeled in parts using several mathematical methods such as:

(i) **Simple geometric shape formulae for areas or solids** Geometric shapes may be used to model structures or their components only if the dimensions and form are identical.

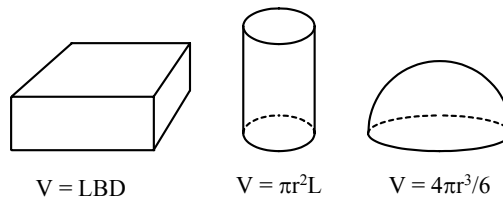

(ii) **Mechanical or electronic instrumentation** Planimeters or electronic digitizing may be used to calculate complex area shapes that render manual integration impracticable.

(iii) **Two-dimensional integration** Two-dimensional integration first determines the sectional area and then multiplies the area by the depth or thickness to derive the volume. It can be used for prismatic forms where the cross-sectional shape, dimensions and area remain the same at all levels of thickness. The cross-sectional area may be modeled using simple geometric area formulae, in whole or in parts, and then multiplied by thickness to derive the volume. If the cross-sectional area is not a standard geometric shape, it should be integrated in whole or in parts.

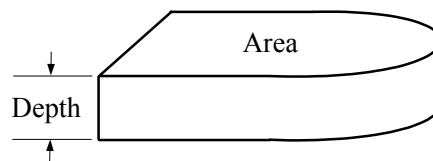

(iv) **Three-dimensional integration** Three dimensional integration is used for complex shapes which cannot be modeled by simple geometric formulae or two-dimensional integration. In this method, area integration (two-dimensional) is followed by volume integration.

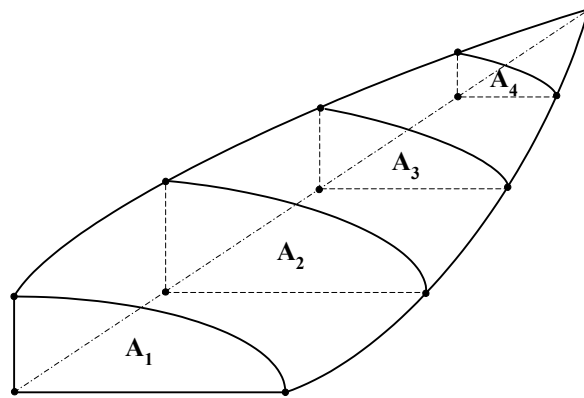

Any mathematical method may be used, provided it accurately models the configuration being measured. Any appropriate area or volume integration method may be used, such as Simpson's First Rule, Trapezoidal Rule, etc. Also, areas or volumes may be integrated along any axis (vertical, horizontal and/or longitudinal) on the vessel as convenient to capture the actual total structure volume.

(v) **Linear Appendages Less Than 1 m² in Area** The volumes of linear appendages of complex shape (e.g., hollow deckhouse overhangs and hollow cockpit coamings) can be calculated by multiplying an average (approximate) sectional area by an average (approximate) length, provided the average sectional area of the appendage is less than one square meter.

(2) **Simpson's First Rule** Simpson's First Rule is intended for integrating areas or volumes under parabolic (second order) curves. When using Simpson's Rule, the end ordinates (those at the "1" multiplier) and the dividing ordinates (those at the "2" multiplier) should coincide with discontinuities and points of inflection in the structure. Discontinuities include breakpoints (knuckles) and steps. Inflections are changes in the direction of a faired curve. Intervals (distances between ordinates) should be adjusted to provide additional ordinates to define extreme curves (rapid changes in the shape).

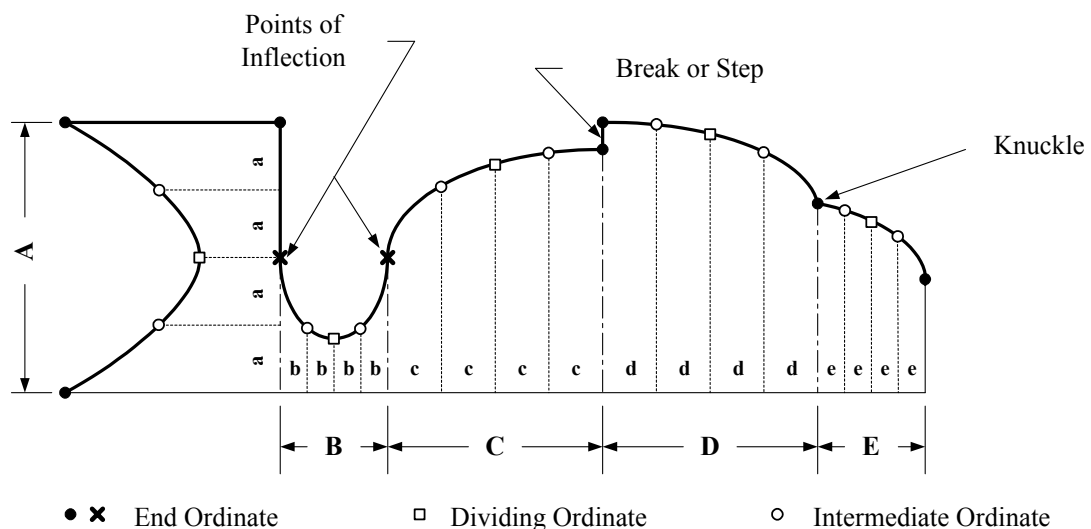

- (3) **Moorsom Method** *The Moorsom method (a variation of Simpson’s First Rule described in 69.109, 69.111 and 69.113) is not an acceptable method for most convention system applications. This is because there are no provisions for placing end or dividing ordinates on discontinuities or inflections or adjustment of intervals (ordinate spacing) for extreme curves, as should be done, unless the structure is properly modeled or measured in parts.*
- (4) **Trapezoidal Rule** *If the Trapezoidal Rule is used to integrate areas under curves, smaller intervals should be used in comparison to those under Simpson’s Rule to increase accuracy. The placement of ordinates is not critical except that they must be coincident with discontinuities (chines, breaks, knuckles, etc.)*

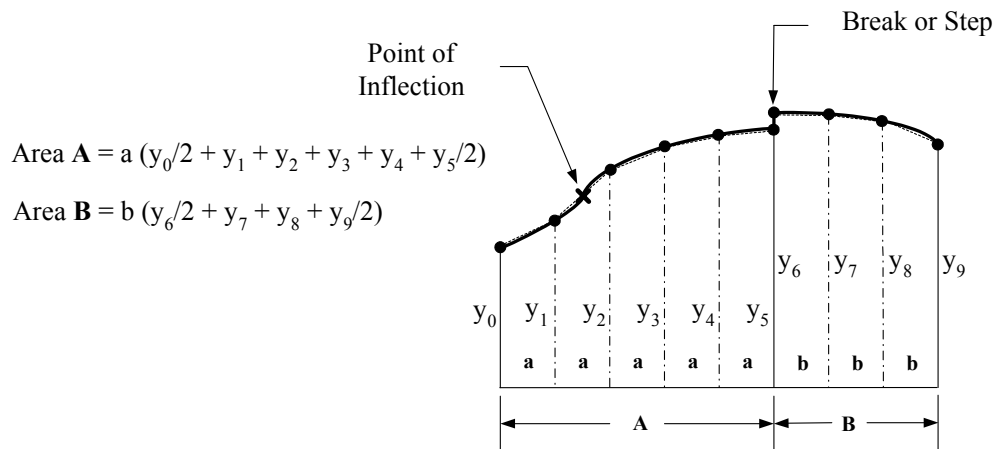

- (5) **Division by Tiers** *Volume accounting does not have to be categorized or broken down by tiers or levels as implied on tonnage certificates. Volumes may be determined by individual structures or erections as necessary and may be itemized as such, in lieu of tier levels.*
- (6) **Restrictions on using § 69.113** *The two-dimensional integration scheme described in § 69.113 may be used for convention measurement only if the:*

(i) *sides of the tier are “wall-sided” with no curved flare or tumble-home,*

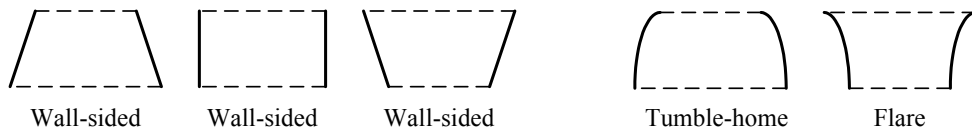

Wall-sided Wall-sided Wall-sided

Tumble-home Flare

Section 69.113 may apply

Section 69.113 cannot apply

- (ii) *deck in plan view does not have discontinuities, inflection points (unless they coincide with end or dividing ordinates) or extreme curves, which would render the suggested Moorsom integration scheme inappropriate, unless the structure is properly modeled or measured in parts.*

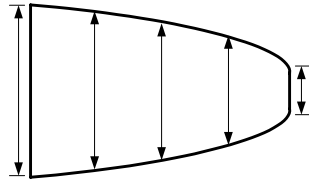

Section 69.113 may apply

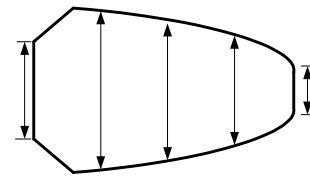

Section 69.113 cannot apply

- (iii) *decks are parallel.*

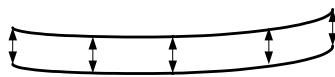

Section 69.113 may apply

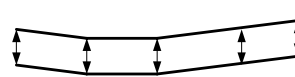

Section 69.113 may apply

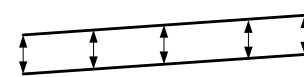

Section 69.113 may apply

(d) TERMINATION OF MEASUREMENTS

Measurements must be taken regardless of the fitting of insulation or the like -

- (1) To the inner side of the shell *of the hull* (or to the inner side of the structural boundary plating for deck structures) in vessels constructed of metal; and
- (2) To the outer surface of the shell *of the hull* (or to the inner side of the structural boundary surfaces for deck structures) in all other vessels. *If the deck structure has framing, dimensions are taken to the inner surface of the skin.*

(e) MEASURING CARGO SPACES

When determining the volume of a cargo space, measurements must be taken without consideration for insulation, sparring, or ceiling fitted within the space. *For vessels which have permanent independent cargo tanks constructed within the vessel, (e.g. gas carriers) the volume to be included should be calculated to the structural boundary of such tanks, irrespective of insulation which may be fitted to the tank boundary.*

(f) PRECISION OF MEASUREMENTS

Measurements must be to the nearest one-twentieth of a foot (*english units*), or the nearest centimeter (*metric units*).

(g) CALCULATION WORKSHEET

Calculations must be made on a worksheet and must be sufficiently detailed to permit easy review. The measurement procedures used must be identified on the worksheet. *If calculations are performed using computer software, printed output showing a description of all dimensional information upon which volumes are based can be substituted for a worksheet. For convenience, when calculating the volume of any enclosed space which includes spaces excluded under § 69.61, it is acceptable to calculate the volume for the entire space and then subtract out the volumes of any associated excluded spaces.*

(h) SPACES IGNORED FROM VOLUME CALCULATIONS

The following spaces are ignored from volume calculations:

- (1) Air Trunks Less Than 1m²** *Air trunks having a cross-sectional area not exceeding one square meter.*

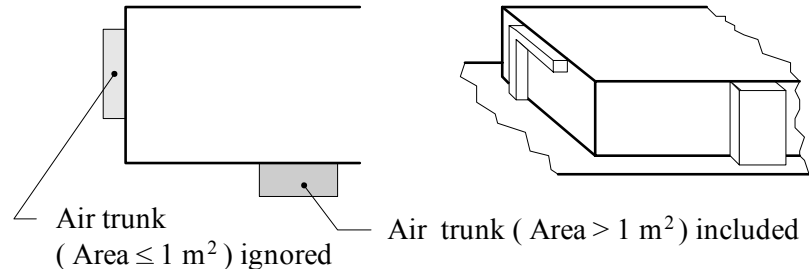

- (2) Volumes Less Than 1m³** *Enclosed spaces having a volume not exceeding one cubic meter.*
- (3) Mast-Like Structures** *Masts, kingposts, cranes (including gantry and mobile cranes), and container support structures which are located above the upper deck and are separated on all their sides from other enclosed spaces, provided the internal volumes are inaccessible.*
- (4) Unenclosed Machinery** *Machinery that is not enclosed by a housing, or similar protective structure (e.g. an unhooused deck winch). Movable lift boat support legs, rudders, propeller shafting, propellers, azimuthing propulsion units, and other movable propulsion, steering or trimming devices are considered machinery in this context.*
- (5) Appendages Not Having Enclosed Volume** *Appendages which do not have enclosed volume, such as bearing struts, solid bilge keels, open frameworks and fenders.*

69.67 MARKING OF CARGO SPACES

Cargo spaces used in determining volume (V_c) for calculating net tonnage must be permanently marked with the letters “CC” (cargo compartment) which are at least four inches in height and positioned so as to be visible at all times. *The marking specifications in 69.119(p)(3) may be used as guidelines.*

69.69 ISSUANCE OF AN INTERNATIONAL TONNAGE CERTIFICATE (1969)

On request of the vessel owner, an International Tonnage Certificate (1969) is issued for a vessel measured under this subpart that is 79 feet or more in registered length and that will engage on a foreign voyage. The Certificate is issued to the vessel owner or master and must be maintained on board the vessel when it is engaged on a foreign voyage.

69.71 CHANGE OF NET TONNAGE

This section provides general requirements on parameters that affect net tonnage, including restrictions governing when newly assigned net tonnages can take effect following a change in net tonnage. The restrictions are intended to prohibit a vessel owner from having lower net tonnages assigned during voyages for which a vessel is unladen (e.g. by having a lower load line assigned for that voyage).

(a) NET TONNAGE INCREASES

When a vessel is altered so that the net tonnage is increased, the new net tonnage must be applied immediately.

(b) VESSEL WITH DIFFERENT LOAD LINE ASSIGNMENTS

A vessel concurrently assigned load lines under both the International Convention on Load Lines (parts 42, 44, 45, or 47 of this chapter) and either the International Convention for the Safety of Life at Sea (SOLAS) (part 46 or 47 of this chapter) or other international agreement must be assigned only one net tonnage. The net tonnage assigned must be the net tonnage applicable to the load line assigned under the International Convention on Load Lines or SOLAS for the trade in which the vessel is engaged.

(c) NET TONNAGE DECREASES

When a vessel is altered so that the net tonnage is decreased or the vessel's trade is changed so that the load line assigned for that trade under paragraph (b) of this section is no longer appropriate and results in a decrease in its net tonnage, a new International Tonnage Certificate (1969) incorporating that net tonnage may not be issued until twelve months after the date on which the current Certificate was issued. However, if one of the following apply, a new Certificate may be issued immediately:

- (1) When the vessel is transferred to the flag of another nation.
- (2) The vessel undergoes alterations or modifications which the Coast Guard deems to be of a major character, such as the removal of a superstructure which requires an alteration of the assigned load line. *For purposes of applying this criterion, any modifications to the extent that the vessel would require remeasurement are considered to be "of a major character".*

69.73 VARIANCE FROM THE PRESCRIBED METHOD OF MEASUREMENT

(a) NOVEL VESSEL DETERMINATION

When application of this subpart to a novel type vessel produces unreasonable or impractical results, the Commandant may determine a more suitable method of measurement.

(b) SUBMITTAL OF DETERMINATION REQUESTS

Requests for a determination must: 1) be submitted to the Commandant, 2) explain the problem, and 3) include plans and sketches of the spaces in question.

69.80 OPEN-TOP CONTAINERSHIPS

The provisions of the 1969 Tonnage Convention should be applied to open-top containerships subject to the following unified interpretations:

(a) UPPER DECK DETERMINATION

In a vessel which is exempted from the requirements to fit weathertight hatch covers on the uppermost deck exposed to weather and sea, as in an open-top containership, the upper deck should be taken as that deck which would have been determined as if such hatch covers had been fitted.

(b) ENCLOSED SPACES

An opening in a deck such as the absence of hatch covers should not preclude a space from being treated as an enclosed space.

(c) TREATMENT OF SHELTER ABOVE CONTAINER STACKS

In the case of open-top containerships having movable non-load-bearing covers (shelter) of light construction resting on the container guides, the space above the hatch coamings up to the covers does not qualify as an excluded space according to regulation 2(5) of the Tonnage Convention. For this particular design, however, an exception can be made in accordance with regulation 1(3). The space can be excluded provided that this type of vessel meets the requirements of an open-top containership without such covers.

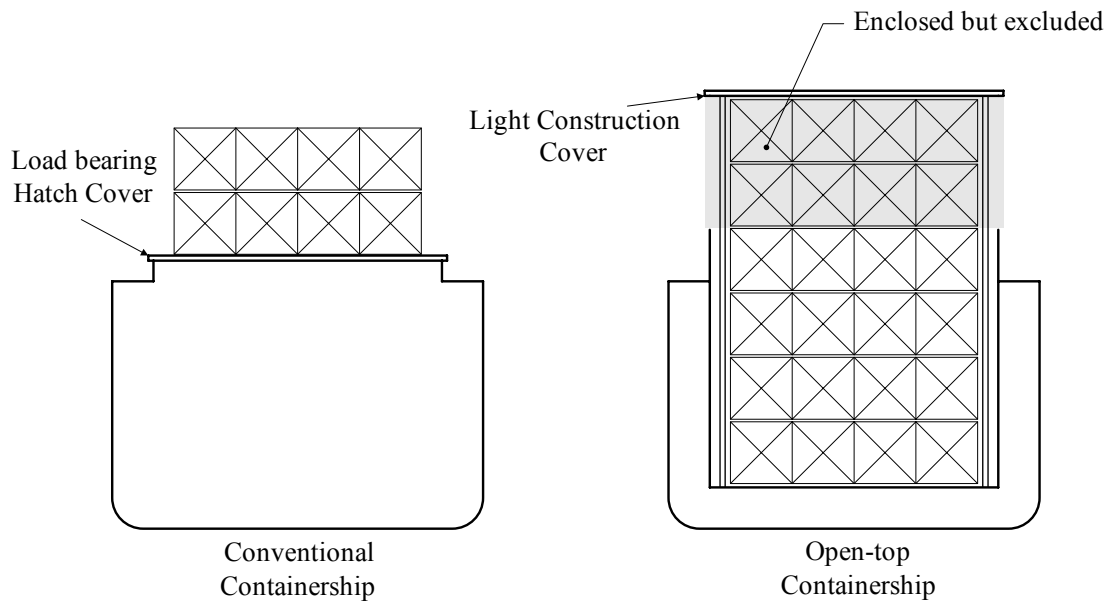

69.81 OFFSHORE SUPPLY VESSELS (OSV'S)

The uncovered cargo deck space on an OSV is not considered an enclosed space under the provisions of §69.73(a), notwithstanding the presence of bulwarks or other enclosing structures that exceed the 5 foot height criteria of §69.59. In this context, the cargo deck space is defined as the open space on the main deck aft of the forecastle that is exposed to weather and used for stowage of deck cargo loads and/or processing equipment. This determination applies to all self-propelled vessels that regularly carry goods, supplies, individuals in addition to the crew, or equipment in support or exploration, exploitation, or production of offshore mineral or energy resources.

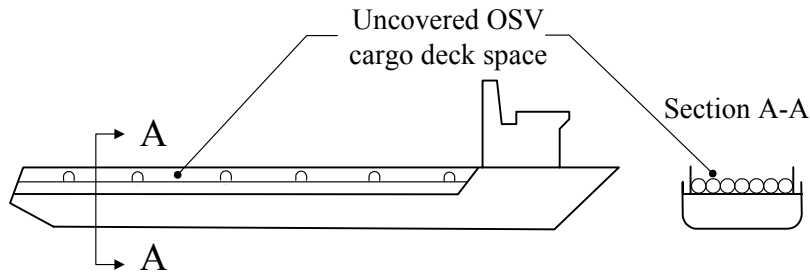

69.85 REDUCED GROSS TONNAGE

IMO Resolution A.747(18) and IMO TM.5/Circ.4 provide for the calculation of a Reduced Gross Tonnage (GT) for qualifying vessels upon request of the vessel owner. Reduced Gross Tonnage is intended to encourage favorable economic treatment of vessels whose designs incorporate specific features. For applicable vessels, a remark is included on a qualifying vessel's International Tonnage Certificate (1969), citing the Reduced Gross Tonnage. The remark includes the statement that the Reduced Gross Tonnage may be used for the "calculation of tonnage based fees." Reduced Gross Tonnage is calculated as follows:

(a) VESSELS WITH QUALIFYING SEGREGATED BALLAST TANKS

The formula for Reduced Gross Tonnage of a vessel with qualifying segregated ballast tanks is provided below. To be considered qualifying segregated ballast tanks, the tanks must have a separate ballast pumping and piping system arranged for the intake and discharge of ballast water from and to the sea only. In addition, there must be no piping connections from segregated ballast tanks to the fresh water system, and the tanks must not be used for the carriage of any cargo or for the storage of ship's stores or material:

$$GT_r = GT - K_1 V_b$$

in which:

GT is as calculated in §69.57

K_1 is as calculated in §69.57

V_b is the total volume of qualifying segregated ballast tanks, calculated in cubic meters.

(b) OPEN-TOP CONTAINERSHIPS

The formula for Reduced Gross Tonnage of an open-top containership is provided below. Reduced Gross Tonnage may be calculated in accordance with this formula only if the vessel's Gross Tonnage (GT) as calculated in §69.57 is 30,000 or less.

$$GT_r = GT [1 - 0.000007(30000 - GT)]$$

in which:

GT is as calculated in §69.57

STANDARD MEASUREMENT SYSTEM



INTERPRETATIONS

TABLE OF CONTENTS

69.101 PURPOSE	4
69.103 DEFINITIONS	4
69.105 APPLICATION FOR MEASUREMENT SERVICES	6
69.107 GROSS AND NET TONNAGES	7
(a) GROSS TONNAGE	7
(b) NET TONNAGE	7
69.109 UNDER-DECK TONNAGE	7
(a) DEFINED	7
(b) METHOD OF CALCULATING TONNAGE.....	7
(c) IDENTIFYING THE TONNAGE DECK	7
(d) ENUMERATING THE DECKS TO IDENTIFY THE SECOND DECK FROM THE KEEL.....	7
(e) IDENTIFYING THE LINE OF THE TONNAGE DECK	8
(f) TONNAGE LENGTH.....	8
(g) DIVISION OF VESSEL INTO TRANSVERSE SECTIONS.....	12
(h) DEPTHS OF TRANSVERSE SECTIONS (<i>see also §69.109(p) and (q)</i>).....	13
(i) BREADTHS OF TRANSVERSE SECTIONS (<i>see also §69.109(p) and (q)</i>).....	14
(j) MEASURING SPACES HAVING CEILING	16
(k) AREA OF TRANSVERSE SECTIONS.....	16
(l) <i>CALCULATING TONNAGE FROM SECTIONAL AREAS</i>	16
(m) STEPS IN DOUBLE BOTTOM (<i>WATER BALLAST</i>).....	16
(n) OUTSIDE SHAFT TUNNEL EXCLUSION.....	17
(o) OPEN VESSELS	17
(p) <i>ORDINARY FRAMES IN MONOHULL VESSELS</i>	17
(q) <i>ORDINARY FRAMES IN MULTIHULL VESSELS</i>	31
69.111 BETWEEN-DECK TONNAGE	34
(a) <i>BETWEEN-DECK TONNAGE</i> DEFINED	34
(b) IDENTIFYING THE LINE OF THE UPPERMOST COMPLETE DECK.....	34
(c) METHOD OF CALCULATING TONNAGE.....	35
69.113 SUPERSTRUCTURE TONNAGE	35
(a) <i>SUPERSTRUCTURE TONNAGE</i> DEFINED	35
(b) METHOD OF CALCULATING TONNAGE.....	35
(c) <i>TREATMENT OF STEPPED DECKS/SIDES</i>	36
(d) <i>COMPUTING SUPERSTRUCTURE TONNAGE</i>	36
(e) <i>TREATMENT OF SPACES OPEN TO UNDER-DECK</i>	36
(f) <i>METHOD OF CALCULATING TONNAGE (STANDARD SHAPES)</i>	36
69.115 EXCESS HATCHWAY TONNAGE	36
(a) <i>APPLICABILITY</i>	37
(b) <i>METHOD OF CALCULATING TONNAGE</i>	37
(c) <i>DETERMINING EXCESS HATCHWAY TONNAGE</i>	37
69.117 SPACES EXEMPT FROM INCLUSION IN GROSS TONNAGE	37
(a) PURPOSE.....	37
(b) SPACES ON OR ABOVE THE LINE OF THE UPPERMOST COMPLETE DECK.....	37
(c) PASSENGER SPACES	38
(d) OPEN STRUCTURES	39
(e) OPEN SPACE BETWEEN THE SHELTER DECK AND THE NEXT LOWER DECK.....	49
(f) WATER BALLAST SPACES	51
(g) METHODS FOR MEASURING EXEMPT SPACES	52

69.119 SPACES DEDUCTED FROM GROSS TONNAGE.....	53
(a) PURPOSE.....	53
(b) GENERAL.....	53
(c) ANCHOR GEAR.....	53
(d) BOATSWAIN’S STORES.....	53
(e) CHART ROOM.....	53
(f) DONKEY ENGINE AND BOILER.....	53
(g) SPACES FOR THE EXCLUSIVE USE OF OFFICERS OR CREW.....	54
(h) MASTER’S CABIN.....	54
(i) RADIO ROOM.....	55
(j) STEERING GEAR.....	55
(k) GENERATORS.....	55
(l) PUMP ROOM.....	55
(m) SAIL STOWAGE.....	55
(n) WASTE MATERIAL SPACE.....	55
(o) PASSAGEWAYS.....	55
(p) MARKINGS FOR DEDUCTIBLE SPACES.....	55
(q) METHOD FOR MEASURING DEDUCTIBLE SPACES.....	56
69.121 ENGINE ROOM DEDUCTION	56
(a) GENERAL.....	56
(b) PROPELLING MACHINERY SPACES.....	56
(c) METHODS FOR MEASURING PROPELLING MACHINERY SPACES.....	57
(d) <i>ENGINE ROOM SPACES ABOVE LINE OF THE UPPERMOST COMPLETE DECK</i>	59
(e) CALCULATING THE ENGINE ROOM DEDUCTION.....	59

STANDARD MEASUREMENT SYSTEM (46 CFR 69 SUBPART C)

69.101 PURPOSE

This subpart prescribes the procedures for measuring a vessel under the Standard Measurement System described in 46 U.S.C. 14512.

69.103 DEFINITIONS

As used in this subpart -

BETWEEN-DECK means the space above the line of the tonnage deck and below the line of the next deck above.

BREAK means the space between the line of a deck and the upper portion of that deck, in cases where that deck is stepped and continued at a higher elevation.

CAMBER means the perpendicular rise or crown of a deck at the centerline of the vessel measured above the skin of the vessel at the vessel's sides.

CEILING means the permanent planking or plating fitted directly on the inboard side of frames, floors, or double bottom and includes cargo battens and refrigeration insulation but does not include false ceiling which stands off from the framing.

COAMING means both the vertical plating around a hatch or skylight and the sill below an opening in a bulkhead.

DECKHOUSE means a structure that is on or above the uppermost complete deck and that does not extend from side to side of the vessel. The term includes cabin trunks and closed-in spaces over the holds of vessels.

DEPTH OF FRAME means the perpendicular depth of a bottom frame and the athwart distance between the inboard and outboard faces of a side frame.

DOUBLE BOTTOM (*WATER BALLAST*) means a space at the bottom of a vessel between the inner and outer bottom plating and used solely for water ballast. *For the space to be considered a double bottom (water ballast), the inner bottom plating must be completely watertight (except for openings to contiguous tanks that are above) and extend continuously fore and aft (interrupted only by peak tanks, cofferdams, and engine rooms) and transversely from one side of the vessel's hull to the other. All accesses to the double bottom (water ballast) must also be watertight.*

FLOOR means a vertical plate or timber extending from bilge to bilge in the bottom of a vessel. In a wooden vessel, "floor" means the lowermost timber connecting the main frames at the keel when that timber extends the full depth of the frames to which it is fastened. In a double bottom, floors usually extend from the outer to the inner bottom.

GROSS TONNAGE is defined in §69.107(a).

HATCH means an opening in a deck through which cargo is laden or discharged.

LINE OF THE ORDINARY FRAMES means the line of intersection of: 1) the imaginary surface running longitudinally that is tangent to the inboard faces of the ordinary frames (or the inside of the vessel's skin, if there are no ordinary frames); and 2) the imaginary plane running transversely through the vessel at the tonnage station of interest, following the application of adjustments as set forth in §69.109(p) and (q). The line established before such restrictions are applied is referred to as the unadjusted line of the ordinary frames. The imaginary surface is derived by using flat surfaces to connect the centerlines of the frame faces.

LINE OF THE TONNAGE DECK means the line determined under §69.109(e).

LINE OF THE UPPERMOST COMPLETE DECK means the line determined under §69.111(b).

NET TONNAGE is defined in §69.107(b).

NORMAL FRAMES are the smallest frames (i.e., frames with the smallest "depth of frame") used to stiffen a structure.

ORDINARY FRAMES are the primary frames used for strengthening the hull.

PARTIAL DECK is any deck that rests directly on floors ("ceiling on floors"), or is a deck below the uppermost complete deck which does not extend from stem to stern and from side to side at all points along its length (as is the case with a "platform" deck that can be accessed only by ladders leading to decks above or below). The presence of a step in a deck will not cause the portions of the deck on either side of the step to be considered partial decks.

REGISTERED BREADTH is defined in §69.53.

REGISTERED DEPTH means "molded depth" as defined in §69.53.

REGISTERED LENGTH is defined in §69.53.

SHELTER DECK means the uppermost deck that would have qualified as the uppermost complete deck had it not been fitted with a middle line opening.

STEP means a cutoff in a deck or in the bottom, top, or sides of a space resulting in varying heights of a deck or varying heights or widths of a space.

SUPERSTRUCTURE means all the permanent structures (such as forecastle, bridge, poop, deckhouse, and break) on or above the line of the uppermost complete deck or, if the vessel has a shelter deck, on or above the line of the shelter deck.

TONNAGE DECK is defined in §69.109(c).

TONNAGE INTERVAL means the longitudinal distance between transverse sections of a vessel's under-deck, between-deck or superstructure when divided into an even number of equal parts for purposes of volume integration.

TONNAGE LENGTH is defined in §69.109(f).

UPPERMOST COMPLETE DECK means the uppermost deck -

- (a) Which extends from stem to stern and from side to side at all points of its length.
- (b) The space below which is enclosed by the sides of the vessel;
- (c) Through which there is no opening that would exempt the space below from being included in gross tonnage; ~~and~~
- (d) Below which there is no opening through the hull that would exempt the space below from being included in gross tonnage, *as in the case of an opposite side tonnage opening;*
- (e) *Which remains above the design waterline of the vessel at all points of its length, except in the case of submersibles, dockships and similar vessels, where the entire uppermost complete deck is submerged during normal operations; and*
- (f) *Which does not rest entirely on floors (ceiling on floors) for a distance of over one-half of the tonnage length. NOTE: While there is an indirect relationship between the one-half of the tonnage length criterion and the number of "zero area" tonnage stations, the criterion must be applied by totaling the length of the deck that rests on floors that qualify as ordinary frames per the definition of §69.103.*

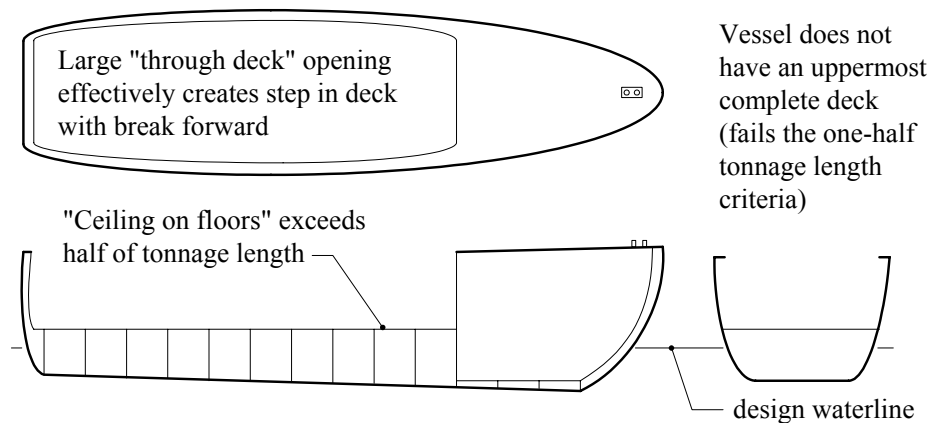

69.105 APPLICATION FOR MEASUREMENT SERVICES

Applications for measurement services under this subpart must include the following information and plans:

- (a) Type of vessel.
- (b) Vessel's name and official number (if assigned).
- (c) Builder's name and the vessel hull number assigned by the builder.
- (d) Place and year built.
- (e) Date keel was laid.
- (f) Overall length, breadth, and depth of vessel.
- (g) Lines plan.

- (h) Booklet of offsets.
- (i) Capacity plans for tanks.
- (j) Construction plans showing measurements and scantlings of hull and superstructure.
- (k) Tonnage drawing showing tonnage length in profile and tonnage sections.
- (l) Arrangement plans.

69.107 GROSS AND NET TONNAGES

(a) GROSS TONNAGE

Gross tonnage is the sum of the following tonnages, less certain spaces exempt under §69.117:

- (1) Under-deck tonnage (§69.109).
- (2) Between-deck tonnage (§69.111).
- (3) Superstructure tonnage (§69.113).
- (4) Excess hatchway tonnage (§69.115(c)).
- (5) Tonnage of framed-in propelling machinery spaces included in calculating gross tonnage (§69.121(d)(1)).

(b) NET TONNAGE

Net tonnage is gross tonnage less deductions under §§69.119 and 69.121.

69.109 UNDER-DECK TONNAGE

(a) DEFINED

“Under-deck tonnage” means the tonnage of the space below the line of the tonnage deck, as that volume is calculated under this section.

(b) METHOD OF CALCULATING TONNAGE

Under-deck tonnage is calculated by applying Simpson’s first rule using the tonnage length and the areas of the tonnage sections prescribed by this section.

(c) IDENTIFYING THE TONNAGE DECK

In vessels with two or less decks, the tonnage deck is the uppermost complete deck. In vessels with more than two decks, the tonnage deck is the second deck from the keel as determined in paragraph (d) of this section.

(d) ENUMERATING THE DECKS TO IDENTIFY THE SECOND DECK FROM THE KEEL

Only decks without openings that permit space below to be exempt from inclusion in under-deck tonnage are enumerated. Partial decks are not considered decks for the purpose of enumerating decks. *Therefore, no portion of an enumerated deck below the uppermost complete deck can rest on floors.* However, the presence of engine and boiler casings, peak tanks, or cofferdams that penetrate a deck do not disqualify the deck from being enumerated.

(e) **IDENTIFYING THE LINE OF THE TONNAGE DECK**

The line of the tonnage deck is established as indicated below.

- (1) **Deck Runs in Continuous Line** If the tonnage deck runs in a continuous line from stem to stern, the line of the tonnage deck is the longitudinal line at the underside of the tonnage deck.
- (2) **Deck Runs at Different Levels** If the tonnage deck runs at different levels from stem to stern, the line of the tonnage deck is the longitudinal line of the underside of the lowest portion of that deck parallel with the upper portions of that deck. Spaces between the line of the tonnage deck and the higher portions of that deck are not included in under-deck tonnage; *rather, they are included in the between-deck tonnage.*

(f) **TONNAGE LENGTH**

- (1) **General** “Tonnage Length” means the length of a horizontal straight line measured at the centerline of the vessel from the point forward where the line of the tonnage deck intersects the line of the inboard faces of the ordinary side frames to the point aft where the line of the tonnage deck intersects the inboard face of the *ordinary* transom frames or cant frames.

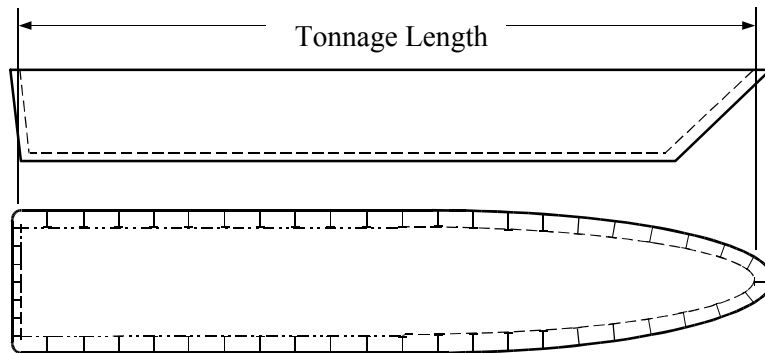

The following additional requirements apply:

- (i) **Complex Stem / Stern Geometries** *For vessels with complex hull geometries at the extreme ends (e.g., SWATH's, monohulls with bulbous bows, etc.), the tonnage length is terminated on an imaginary plane that is perpendicular to the longitudinal axis of the vessel and tangent to the imaginary surface bounding the inboard faces of the ordinary frames at the extreme fore and aft location of this surface.*

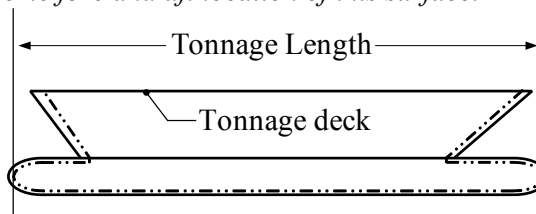

(ii) *“Deep Framed” Sections* If the last two ordinary side frames (or alternating ordinary side frames) at the bow/stern of the vessel are solid side-to-side “deep” frames (no sectional area), then the tonnage length is terminated at the location where the vertical plane on the longitudinal axis of the vessel intersects the imaginary surface that is tangent to the inboard faces of the ordinary stem, stern or cant frames at the line of the tonnage deck. In the absence of ordinary stem, stern or cant frames, the tonnage length is terminated on the inside of the vessel’s skin at the extreme end of the vessel.

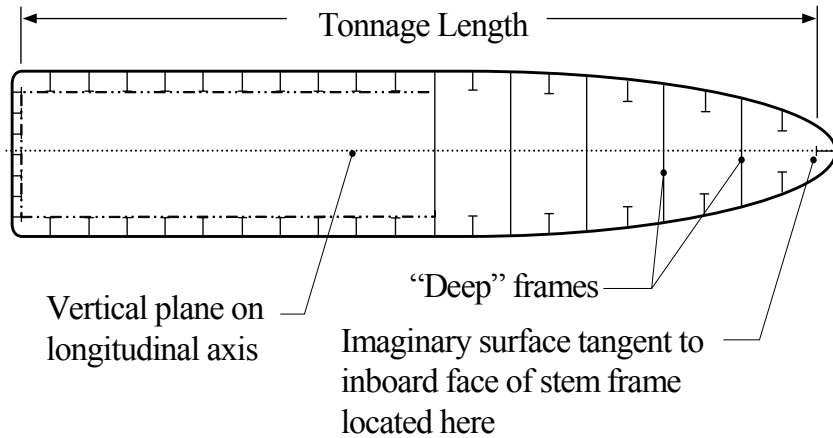

(2) **Vessel With Headblock or Square End** For a vessel with a headblock or square end with framing which extends from the tonnage deck to the bottom of the vessel, the tonnage length terminates on the inboard face of the head block or end framing. When a headblock extends inboard past the face of the end frames or side frames, or when the headblock plates are excessive in length, the tonnage length terminates at the extreme end of the vessel less a distance equal to the thickness (i.e., depth) of an ordinary side frame and shell plating. *Headblock plates are longitudinal structural plates at the extreme ends of the vessel that do not qualify as ordinary frames. In order to be considered "excessive in length" the headblock plate length is such that the presence of such a plate would cause a decrease in the tonnage length from that which would have been obtained were the plates not installed.*

WOOD CONSTRUCTION

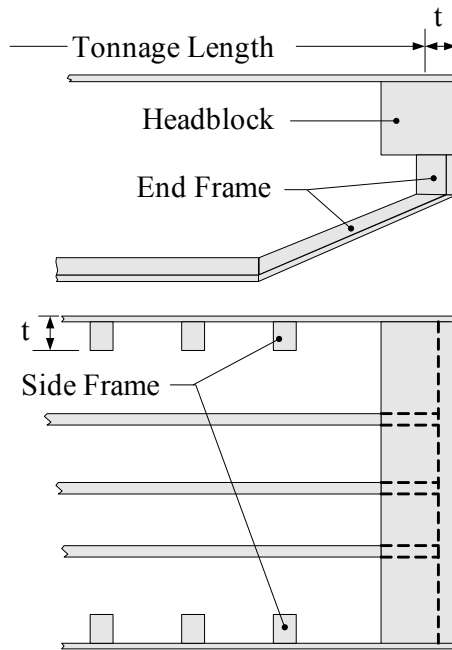

STEEL CONSTRUCTION

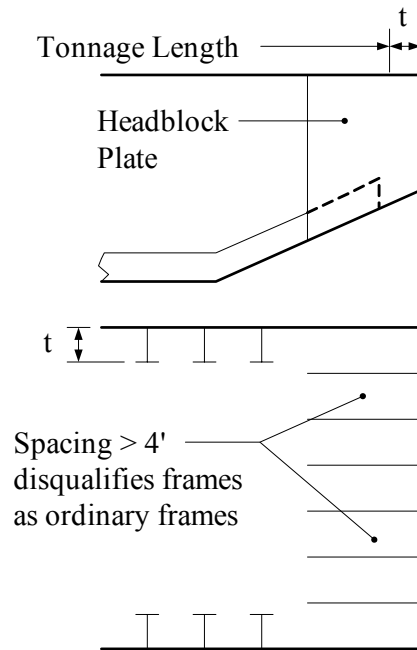

- (3) **Camber** For a vessel having a square bow or stern and tonnage deck with camber, the effect of the camber on the tonnage length must be considered. The tonnage length must be measured below the tonnage deck at a distance equal to one-third of round camber and one-half of straight pitch camber.

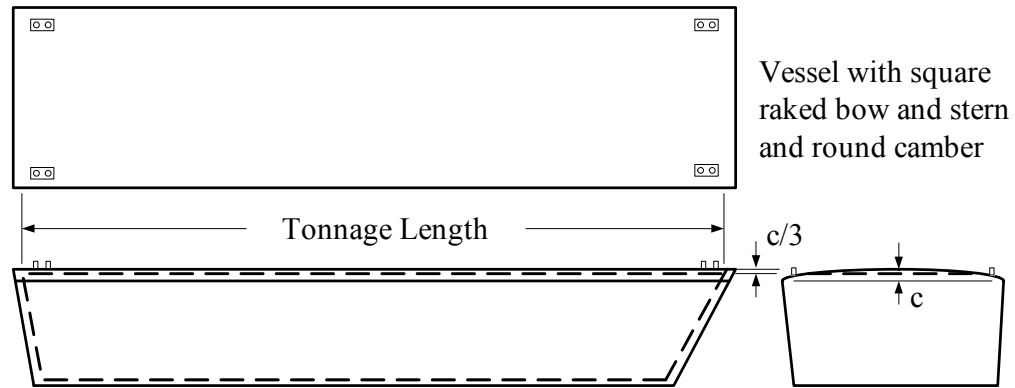

- (4) **Restrictions on Termination Points** The following restrictions apply to the tonnage length termination points:

- (i) The horizontal distance in the longitudinal direction from the termination point to the associated inboard surface of the skin of the hull at the bow or the stern cannot exceed 8.5 feet.

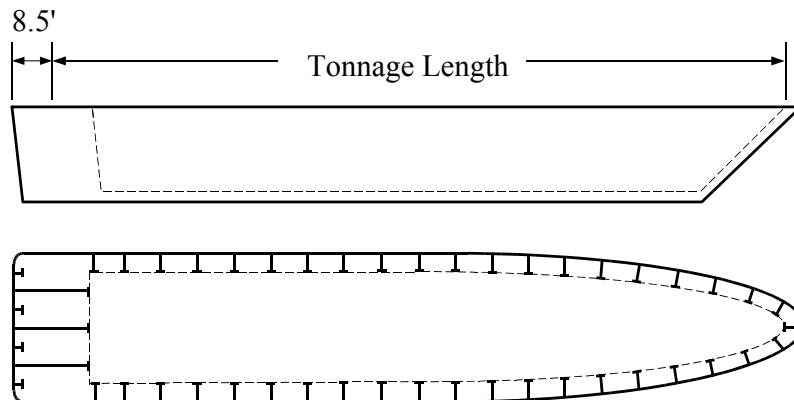

- (ii) The forward termination point must be forward of the intersection of the centerline and face of the foremost transverse ordinary frame; and

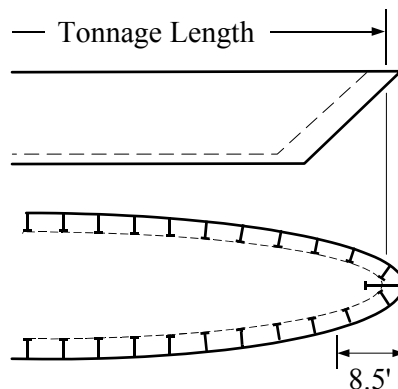

(iii) The after termination point may not be located forward of either: 1) the intersection of the centerline and face of the aftermost transverse ordinary frame; or 2) the forward side of the rudder stock (excepting vessels with exterior rudder stocks).

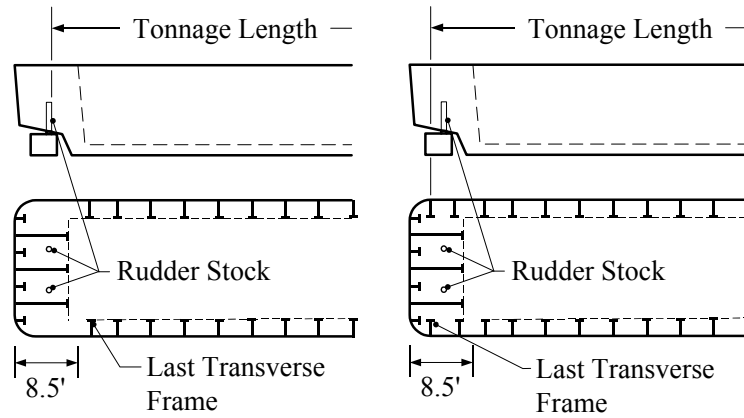

(g) DIVISION OF VESSEL INTO TRANSVERSE SECTIONS

(1) Number of Divisions Except as under paragraph (m)(1)(iii) of this section, the tonnage length is divided into an even number of equal parts as indicated in the following table:

CLASS	TONNAGE LENGTH (FT)	DIVISIONS	STATIONS
1	$L \leq 50$	6	7
2	$50 < L \leq 100$	8	9
3	$100 < L \leq 150$	10	11
4	$150 < L \leq 200$	12	13
5	$200 < L \leq 250$	14	15
6	$L > 250$	16	17

(2) Location of Stations Transverse sections are cut at each end of the tonnage length and at each point of division of the tonnage length. Intervals and one-third intervals (defined in paragraph (k)(5) of this section) between the points of division are measured to the nearest thousandth of a foot.

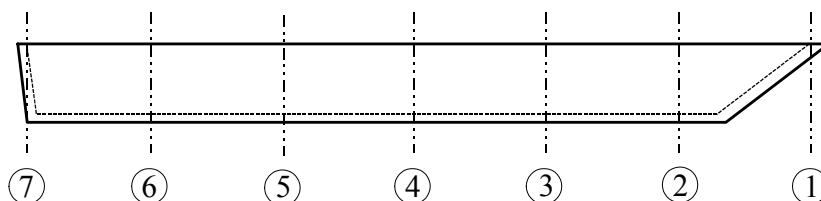

(h) DEPTHS OF TRANSVERSE SECTIONS (see also §69.109(p) and (q))

- (1) **General** Transverse section depths are measured at each point of division of the tonnage length at the centerline of the vessel from a point below the line of the tonnage deck equal to one-third of the camber or to one-half of the pitch of the beam down to the lowest portion of the upper side of the ordinary frames, floors, longitudinals, or tank top of a cellular or other qualifying double bottom (water ballast), as the case may be. Floors and longitudinals in this context are specific types of ordinary frames. If no frames qualify as ordinary frames, depths are terminated at the inner surface of the hull shell.

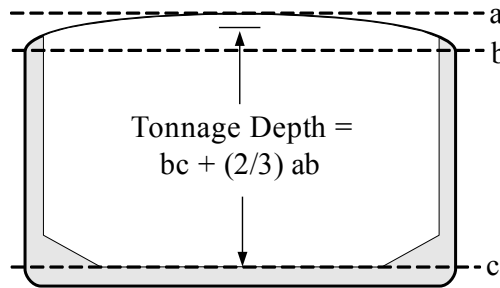

- (2) **Tank Top Fall** When a depth falls at a point where the tank top of a double bottom (water ballast) has a straight fall from centerline to the wings, the depth terminates at one-half of the height of fall.

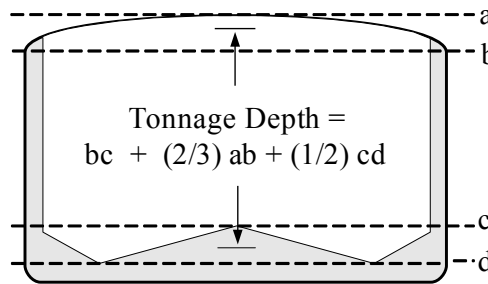

- (3) **Tank Top Rise** When a depth falls at a point where the tank top of a double bottom (water ballast) rises from the centerline to the wings, the depth terminates at one-half the dead rise.

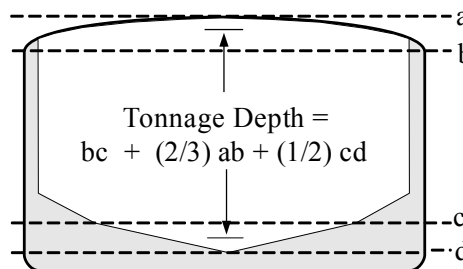

- (4) **Number of Depth Increments** The depth at the midpoint of the tonnage length or, when a vessel is measured in parts, the depth at the midpoint of each part determines the number of equal parts into which each depth is divided, as follows:

- (i) Midpoint Depth Criterion If the midpoint depth is 16 feet or less, each depth is divided into four equal parts. If the midpoint depth exceeds 16 feet, each depth is divided into six equal parts.

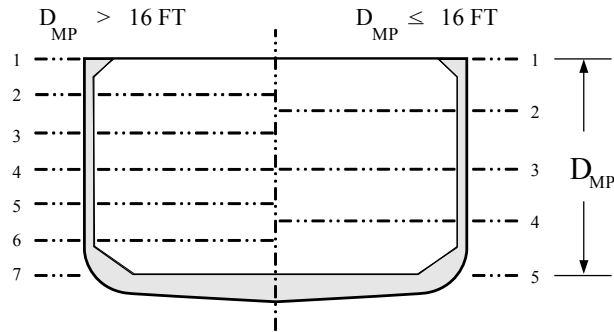

- (ii) Rounding The interval between the points of division of a depth and one-third intervals are carried to the nearest hundredth of a foot.

(i) **BREADTHS OF TRANSVERSE SECTIONS** (see also §69.109(p) and (q))

- (1) **General** Transverse section breadths are measured horizontally at each point of division of each depth and also at the upper and lower points of each depth. Breadths are measured to the inboard face of the ordinary frames or to the line of the ordinary frames. Breadths are measured parallel to each other and at right angles to the vessel's centerline.

Transversely Framed Vessel

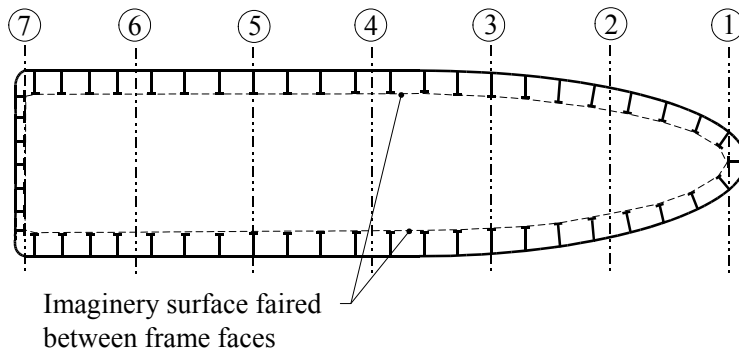

Longitudinally Framed Vessel

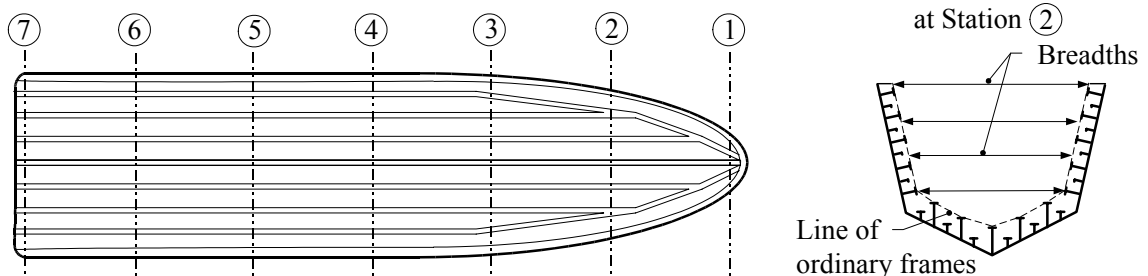

- (2) **Deck Brackets and Camber** Upper breadths are not reduced by measuring to deck-beam brackets. In cases of camber where an upper breadth passes through the deck, the breadth is measured to the line of the side frames at the underside of the deck projected vertically up to the height of the upper breadth.

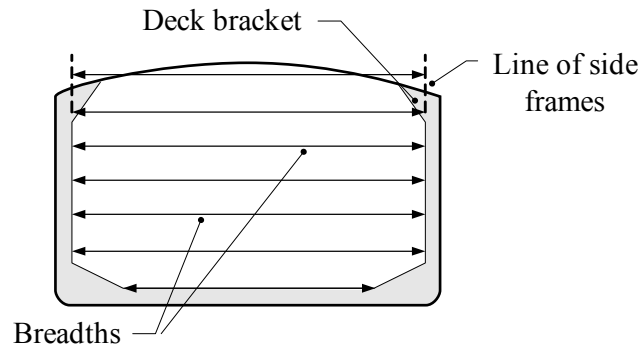

- (3) **Dead Rise** Bottom breadths are measured only as far as the flat of the floor extends. When bottom frames rise immediately from the flat keel, bottom breadths are equal to the breadth of the flat keel. Where there is no double bottom (*water ballast*) and where there is dead rise of the bottom out to the sides of the vessel, bottom breadths are equal to the part of the bottom plating not affected by dead rise.

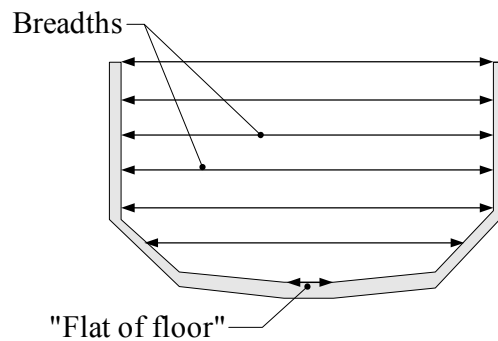

- (4) **Sloping Double Bottom (Water Ballast)** Bottom breadths falling in way of a double bottom (*water ballast*), the top of which rises or falls from centerline to the wings, are measured between the inboard faces of the frame brackets which connect the double bottom (*water ballast*) with the frames.

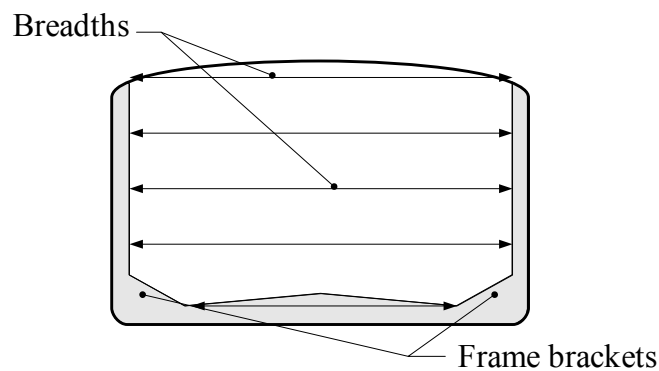

(j) MEASURING SPACES HAVING CEILING

The maximum allowance for terminating measurements on ceiling is three inches on the bottom frames or tank top and three inches on each side frame. When ceiling is less than three inches thick, only the actual thickness is allowed. When ceiling is fitted on a platform directly above the bottom frames, depths are measured down through the platform to the upper side of the frames and the allowable ceiling on the platform is then deducted.

(k) AREA OF TRANSVERSE SECTIONS

Areas at each transverse section are calculated as follows:

- (1) Areas at Extremities of Tonnage Length** A transverse station at the end of the tonnage length may not yield area, except in vessels (such as barges) with an upright bow or stern.
- (2) Numbering of Breadths** The breadths of each transverse section are numbered from above, the upper being "1", the second being "2", and so on to the lowest.
- (3) Applying Multiplication Factors** Multiply the even numbered breadths by four and the odd numbered breadths by two, except for the first and last breadths, which are multiplied by one.
- (4) Summing Products** Add together the products from paragraph (k)(3) of this section.
- (5) Final Area Calculations** Multiply the sum from paragraph (k)(4) of this section by one-third of the interval between the breadths. The product is the area of the transverse section.

(l) CALCULATING TONNAGE FROM SECTIONAL AREAS

The total under-deck volume and tonnage is calculated as follows, using the areas determined in paragraph (k)(5) of this section:

- (1) Numbering Stations** Number the transverse sections successively "1", "2", and so forth, beginning at the bow.
- (2) Applying Simpson's Multipliers** Multiply the area of the even numbered sections by four and the area of the odd numbered sections by two, except the first and last sections, which are multiplied by one.
- (3) Completing Volume Calculations** Add together the products from paragraph (l)(2) of this section and multiply the sum by one-third of the interval between the sections. The product is the volume under-deck.
- (4) Converting to Tonnage** The volume under-deck is divided by 100 and is, subject to exemptions, the under-deck tonnage.

(m) STEPS IN DOUBLE BOTTOM (WATER BALLAST)

This section provides general requirements for measurement "in parts" of monohull vessels having stepped double bottoms (water ballast) where the height of the step(s) exceeds six inches.

- (1) Division into Parts** The tonnage length of a vessel having a step exceeding six inches in height in its double bottom (*water ballast*) is divided into longitudinal parts at the step. Each part is subdivided as follows to determine the number of transverse sections:
 - (i) Parts 20 feet or under in length are divided into two equal parts.

- (ii) Parts over 20 feet and under 40 feet in length are divided into four equal parts.
 - (iii) Parts 40 feet or over are divided as provided in paragraph (g)(1) of this section.
- (2) **Summation of Tonnages** The tonnage of each part is calculated separately. The sum of the tonnages of the parts is the under-deck tonnage.
- (n) **OUTSIDE SHAFT TUNNEL EXCLUSION**
Any portion of an outside shaft tunnel included in tonnage through the process of measurement is subtracted from the under-deck tonnage.
- (o) **OPEN VESSELS**
- (1) **Definition** An open vessel is one of any length without a deck or with one or more partial decks, the total length of which is less than one-half the tonnage length. *In other words, an open vessel is one without an uppermost complete deck.*
 - (2) **Line of the Tonnage Deck** The line of the tonnage deck for an open vessel is the upper edge of the upper strake. Depths of transverse sections are taken from this line.
 - (3) **Restrictions on Smaller Vessels** Any vessel, other than one having a mechanically refrigerated hold, that is not an open vessel and that has a tonnage length of less than 50 feet is measured as an open vessel, if the distance between the line of its tonnage deck and the upper edge of the upper strake is more than one-sixth of the midship depth. "Midship depth" means the depth measured from the line of the upper edge of the upper strake to the point in the bottom used for measuring tonnage depths.
- (p) **ORDINARY FRAMES IN MONOHULL VESSELS**
This section provides specific interpretations relative to ordinary framing in monohull vessels. The ordinary frames must first be identified in order to determine depth and breadth measurements under §69.109 (h) and (i).
- (1) **Ordinary Frame Construction** *The following apply to the construction of ordinary frames and floors:*
 - (i) **Frame Intersection** *A frame may not be considered to be an ordinary frame if it is penetrated by an intersecting frame (or other structural element such as plating) that is used to strengthen the vessel's hull, except in the case of floors in vessels of wooden construction. In wooden vessels, an ordinary floor may be penetrated by an intersecting frame, provided it is attached to the intersecting frame. In vessels of other than wooden construction, an ordinary frame may be penetrated by an intersecting frame when initially assembled, provided subsequent manufacturing steps are taken to render the final assembly to appear as an integral unit (such as by continuous welding).*
- NOTE: The practice of allowing one longitudinal side frame and one longitudinal bottom frame to penetrate a transverse ordinary frame in vessels of other than wooden construction is no longer authorized.*

- (ii) Material Ordinary frames must be of the same material as the adjacent hull. If a portion of the frame is not of the same material as the adjacent hull, that portion is treated as if it were not there for purposes of establishing breadth and depth measurements. The Marine Safety Center will consider written requests for exceptions to this requirement, if it can be demonstrated that the frame material strength equals or exceeds the hull material strength.

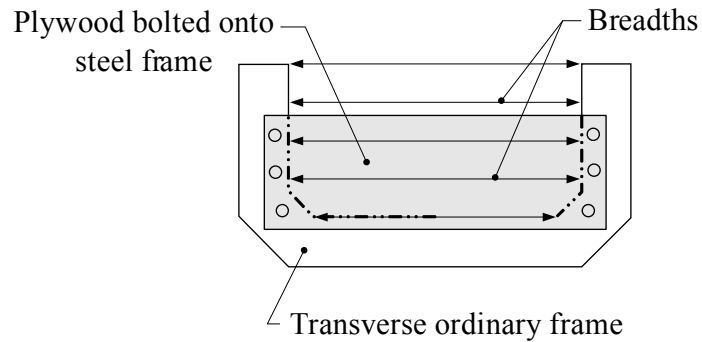

- (iii) Attachment to Hull Each frame must attach to the hull to at least the same extent as adjacent ordinary and normal framing. For example, if an adjacent ordinary frame is attached to the hull with a continuous fillet weld on both sides of the web, the frame in question must also be attached to the hull with a continuous fillet weld on both sides of the web. If this criteria is not met, then the entire frame may not be considered as an ordinary frame.
- (iv) Framing Comprised of Different Elements If an ordinary frame is comprised of different distinct elements, those elements must be permanently bonded together (e.g., welded, glued or bolted) to form a continuous and integral unit. Individual components must be attached to each other in the same (or equivalent) manner and to the same extent that the frame is joined to the hull. If an element of the frame does not meet any of these criteria, that element is treated as if it were not there for purposes of establishing breadth and depth measurements.

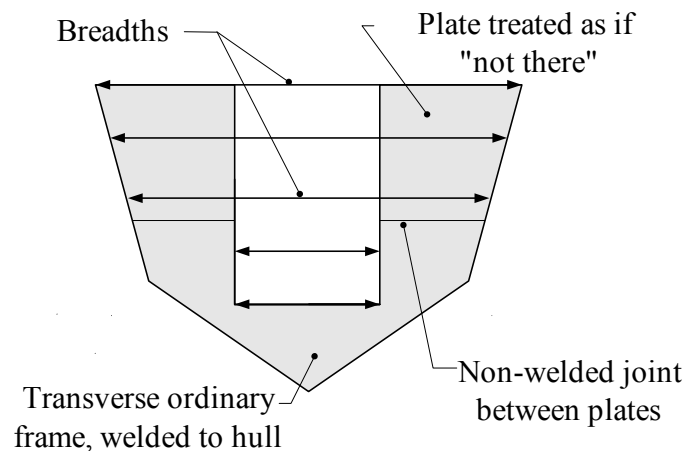

NOTE: There are no longer any restrictions on the relative thicknesses of the different frame elements.

(2) **Transverse Framing** *The following additional requirements apply to those vessels fitted with transverse ordinary frames:*

- (i) **General Requirements** *In order to be used as the basis for establishing the line of the ordinary frames, the ordinary frames must be spaced on centers that are a maximum of four (4) feet apart for a length of at least one tonnage interval (L_{TI}) either crossing, beginning at, or ending at the tonnage station of interest. Otherwise, the line of the ordinary frames is taken at the inboard surface of the skin of the hull at the tonnage station of interest.*

Example 1

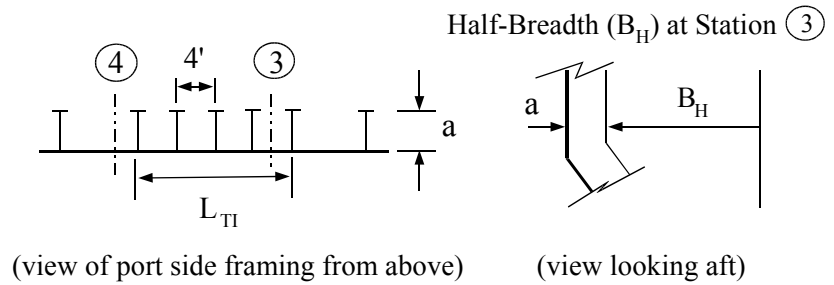

Example 2

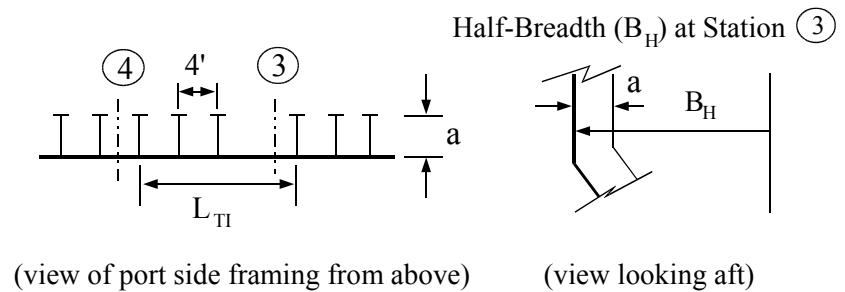

(ii) Different Sized Framing If the ordinary frames are of different sizes (i.e., differing “depths of web”), the line of ordinary frames is established using the largest sized ordinary frames that alternate with smaller or equal sized ordinary frames for a length of at least one tonnage interval (L_{TI}) either crossing, beginning at, or ending at the tonnage station of interest. If the alternating larger frames are not of equal size, then the smallest frame of the selected set of alternating larger ordinary frames is used to establish the line of the ordinary frames.

Example 1

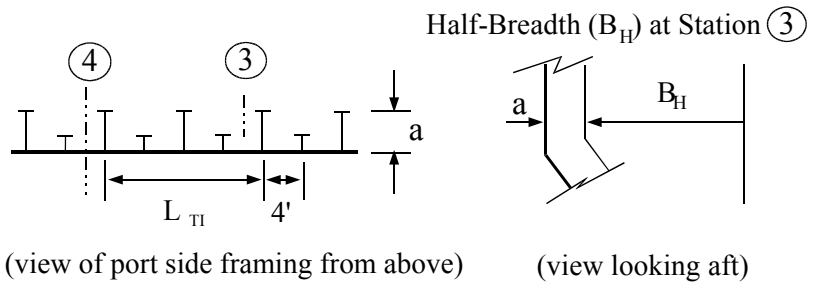

Example 2

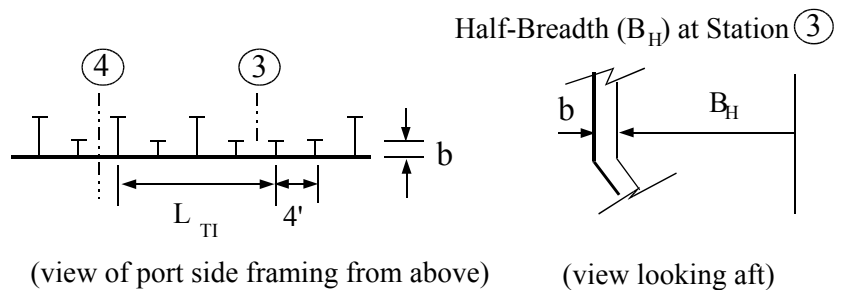

(iii) Openings If an opening in an ordinary frame (e.g., lightening hole) exceeds a diameter of 18" (all locations except fuel tanks) or a size of 15" wide by 23" high (fuel tanks only), the opening is considered to be oversized, and the line of the ordinary frames is established as if the frame material above and inboard of the opening were not there.

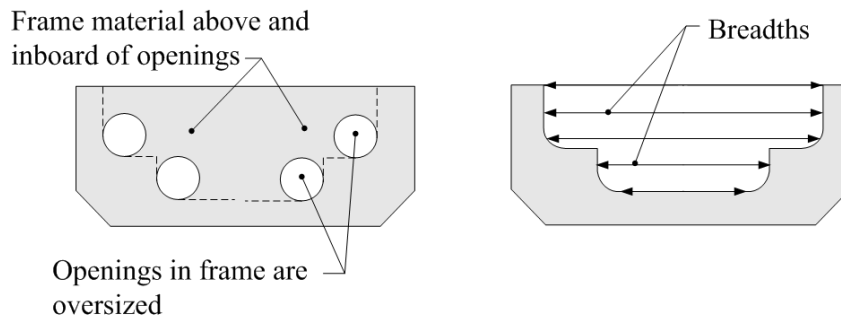

Piping, ventilation, cabling, shafting and similar items of a non-structural nature may be run through the openings without affecting breadth measurements. The following specific interpretations regarding ordinary frame openings also apply:

- (1) Equivalent Sized Openings To determine whether openings of different shapes are oversized openings as defined in §69.109(p)(2)(iii) above, calculate the areas of the openings. Openings that are larger than 254.5 square inches (all locations except fuel tanks) or 345 square inches (fuel tanks only) are treated as oversized openings. These areas relate to the size criteria of §69.109(p)(2)(iii). The 254.5 square inch area for all locations except fuel tanks is equivalent to the 18" diameter criterion and the 345 square inch area for fuel tanks only is equivalent to the 15" wide by 23" high criterion.

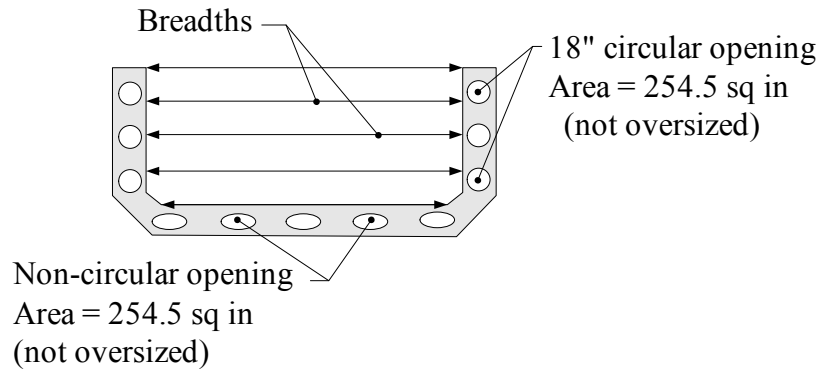

- (2) Proximity of Openings Except as permitted by §69.109(p)(2)(iii)(4), frame openings that are within the longest linear dimension of any adjacent opening are treated as if the frame material separating the openings were not there.

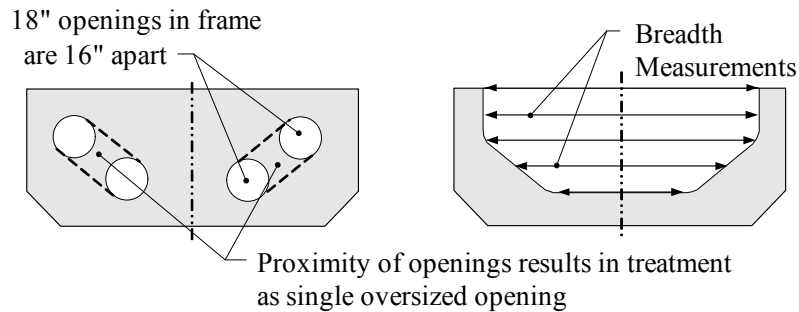

- (3) Location of Openings Openings that are not oversized may be situated in any location within, or along the outboard edge of, the frame without affecting the line of the ordinary frames. A "notch" at the upper edge of a deep transverse frame is considered to be an opening "within" the frame when there is decking present that effectively serves as the flange for the web.

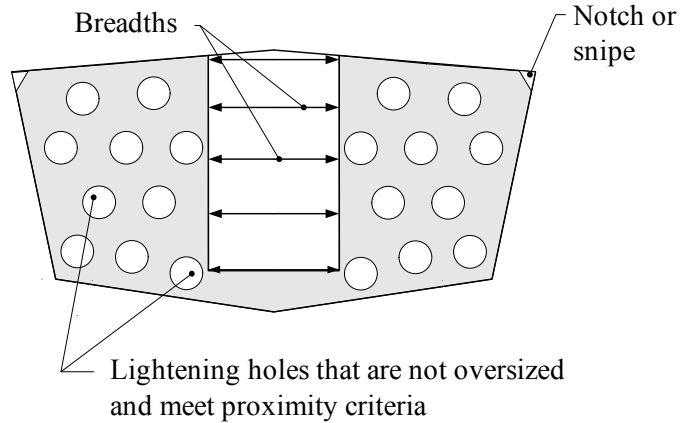

- (4) Strapping The attachment of a single strap across an oversized opening is considered an acceptable method of reducing the size of the opening. The final "strapped" configuration must meet all of the requirements of §69.109(p)(1) and §69.109(p)(2)(iii)

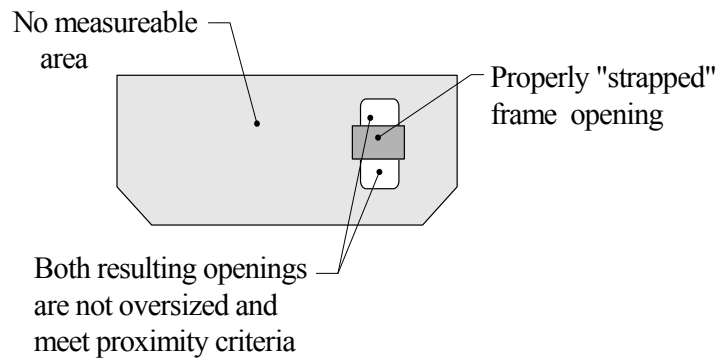

NOTE: Use of a single 1" wide strap is no longer an acceptable method of reducing the size of an oversized opening.

- (5) Intersecting Structural Members If a structural member passes through an opening that is not oversized, that opening shall be treated in the same manner as an opening that is oversized. Under the requirements of §69.109(p)(1)(i), an intersecting structural member that is used to strengthen the vessel's hull would preclude the frame from being considered as an ordinary frame, regardless of opening size, if it passes through the frame opening

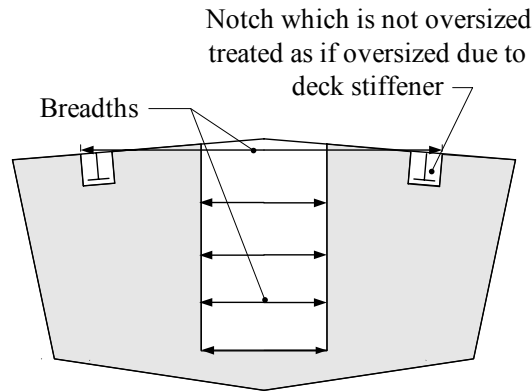

- (iv) Vertical Continuity of Framing In order to be considered an ordinary side frame, the frame must extend from the turn of bilge up to the line of the tonnage deck, with a measurable "depth of frame" at all points along its length. If the former condition is not met, the portion of a side frame above the turn of bilge is treated as if it were not there.

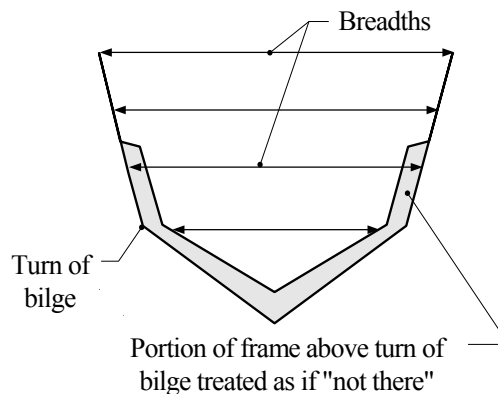

NOTE: Requirements of §69.109(p)(4) on attachment of transverse bottom floors or framing to ordinary side frames preclude alternating transverse side frames and bottom floors from being considered as ordinary frames.

- (v) *Adjustments to the Line of the Ordinary Frames* Except in situations involving tumblehome, the line of the ordinary frames is established as if the portions of frames that are above and inboard of the outboard most point along the unadjusted line of the ordinary frames were not there. In situations involving tumblehome, the line of the ordinary frames should “follow the hull” above this outboardmost point.

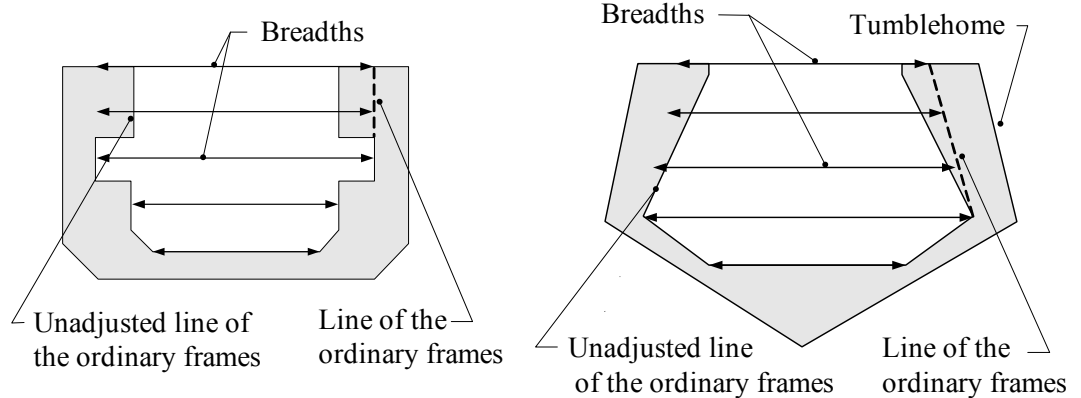

(3) Longitudinal Framing The following apply to vessels fitted with longitudinal ordinary frames:

- (i) *General Requirements* In order to be used as the basis for establishing the line of the ordinary frames, the ordinary frames must be spaced on centers that are a maximum of four (4) feet apart, and must begin and end at a transverse ordinary frame or at the vessel's hull. The framing must run the length of at least one tonnage interval (L_{TI}) either crossing, beginning at, or ending at the tonnage station of interest. If these requirements are not met, the line of the ordinary frames is taken at the inboard surface of the skin of the hull at the tonnage station of interest. Also, if the uppermost ordinary frame is below but within 4 feet of the line of the tonnage deck, the upper portion line of the line of the ordinary frames is taken as the continuation of the line drawn between the faces of the upper two ordinary frames (before applying any adjustments under §69.109(p)(4)(iv) below).

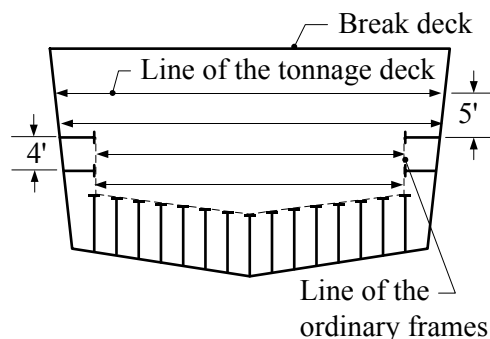
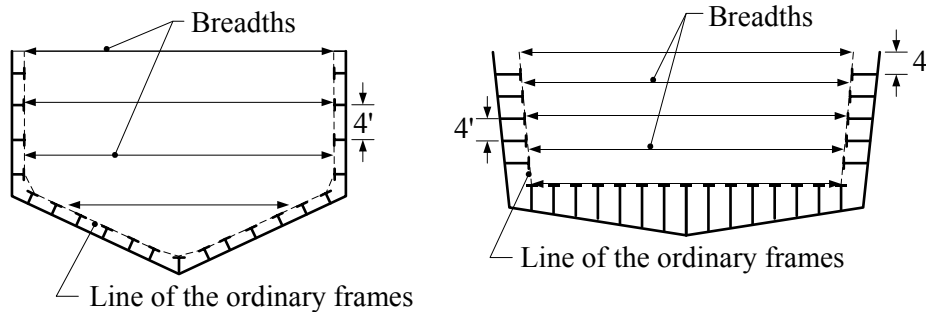

NOTE: There are no restrictions regarding the size of ordinary side frames.

- (ii) Different Sized Framing If the ordinary frames are of different sizes (i.e., differing “depths of frame”), the set of alternating frames that yields the smallest sectional area at the associated tonnage station is used to establish the line of the ordinary frames. Different sets of bottom frames and side frames may be selected in order to yield the smallest sectional area, provided there are at least two alternate ordinary frames in each set.

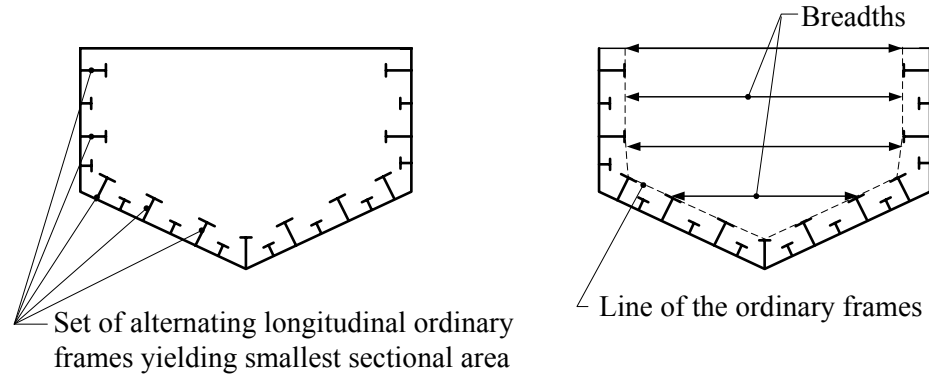

- (iii) Frame Openings The size and spacing requirements of §69.109(p)(2)(iii) for openings in transverse ordinary frames also apply to openings in longitudinal ordinary frames. If these requirements are not met, the line of the ordinary frames is established as if the portion of the frame above and/or inboard of the outboard-most edge of the opening were not there.

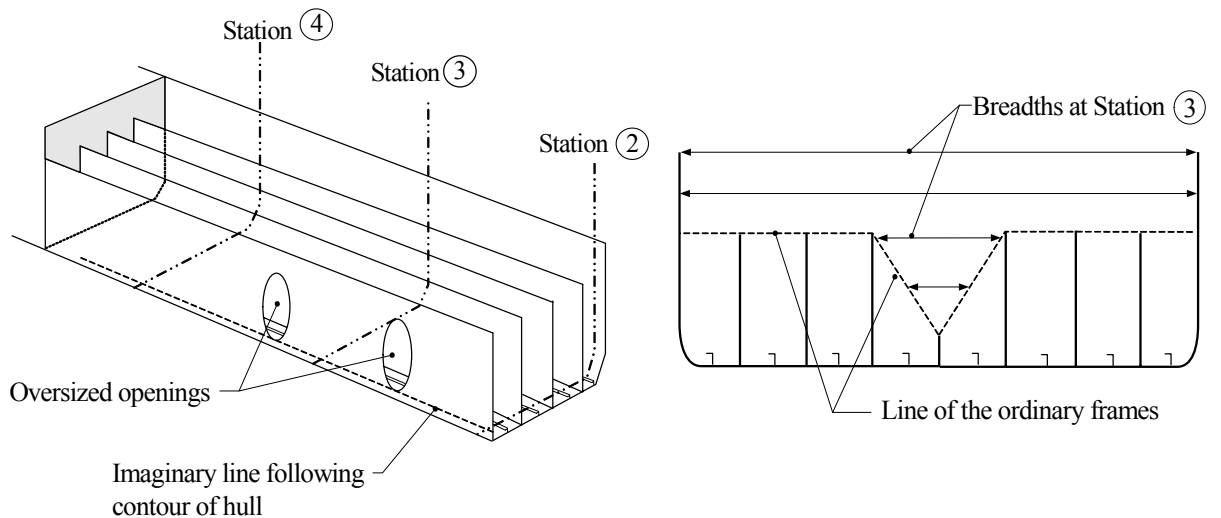

- (iv) Longitudinal Framing vs. Bulkheads There is no longer a requirement to notch in the upper edge of a longitudinal bulkhead in order to qualify that bulkhead as an ordinary longitudinal frame.

(v) Requirements for Terminating Transverse Frames For the case of longitudinal ordinary frames that end on a transverse frame, the following requirements apply to the terminating transverse frames:

(1) Portions of Frames Above Terminating Frames The portions of those longitudinal frames that are above/inboard of the terminating transverse frames are treated as if they were not there when establishing the line of the ordinary frames.

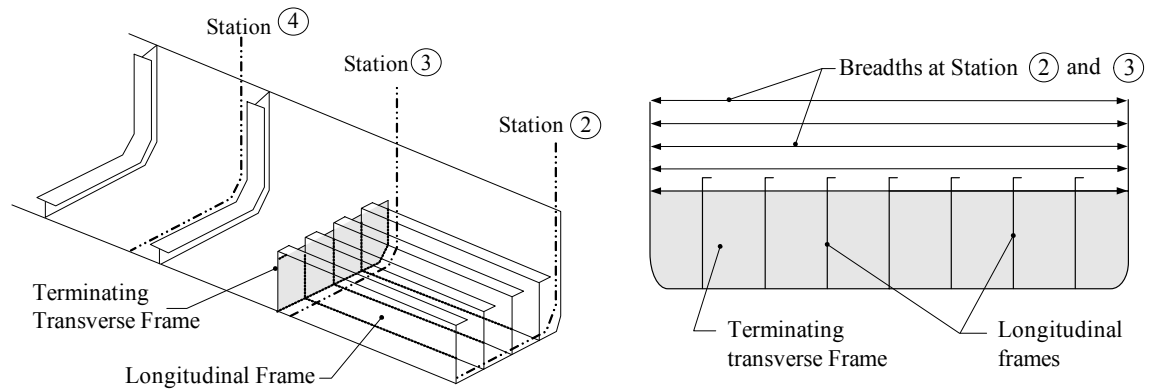

(2) Oversized Openings If an opening in a terminating transverse frame(s) were oversized as defined in §69.109(p)(2)(iii) and overlaps any portion of a longitudinal ordinary frame, the portion of the longitudinal ordinary frame that is above the opening is treated as if it were not there when establishing the line of the ordinary frames. The same treatment applies to a combination of openings whose proximity creates a single oversized effective opening under the criteria of §69.109(p)(2)(iii)(2).

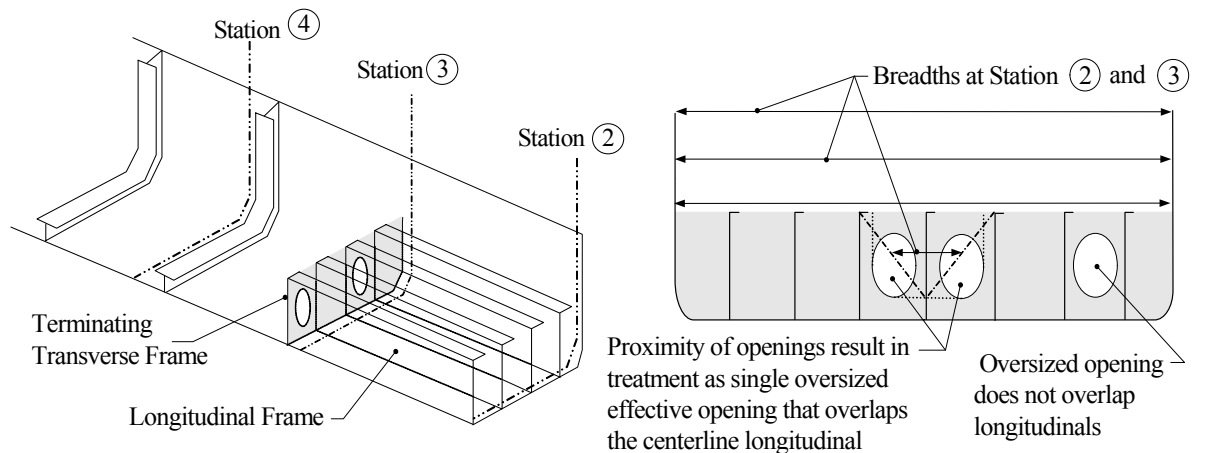

(vi) *Transition Between Side and Bottom Frames* In order for the lowest frame in a longitudinal side framing sequence to be considered as an ordinary frame, its centerline must be located within 4 feet of the bottom skin of the hull, an ordinary bottom frame or floor used to establish the line of the ordinary frames, or the inner bottom in the case of a double bottom (water ballast). If the lowest frame does not meet this condition, the line of the ordinary frames is established as if all longitudinal side frames were not there.

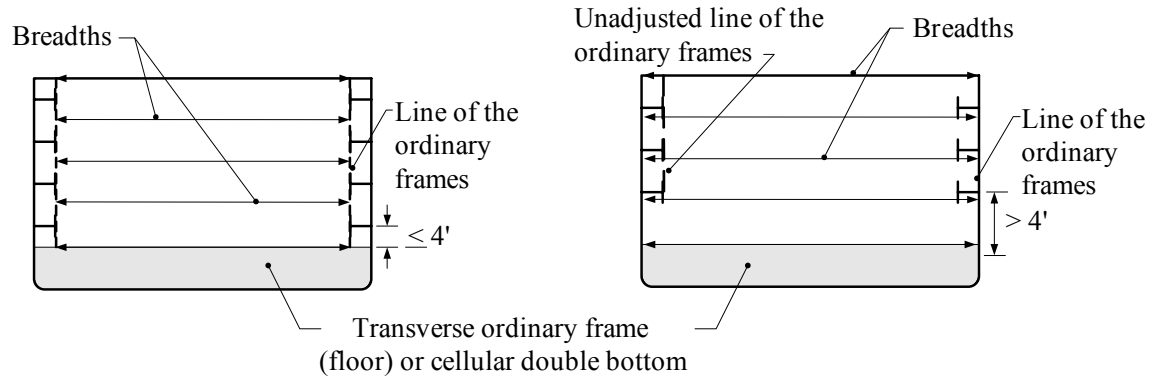

(vii) Adjustments to the Line of the Ordinary Frames Except in situations involving tumblehome, the line of the ordinary frames is established as if the portions of frames that are above and inboard of the outboard most point along the unadjusted line of the ordinary frames were not there. In situations involving tumblehome, the line of the ordinary frames should “follow the hull” above this outboardmost point. Also, where an ordinary bottom frame (or double bottom (water ballast) tank top) is outboard of the inboard face of an ordinary side frame, the line of the ordinary frames is adjusted so that it runs vertically from the inboard face of the lowest ordinary side frame that is above the line of the ordinary frames down to the line of the ordinary bottom frames (or double bottom (water ballast) tank top).

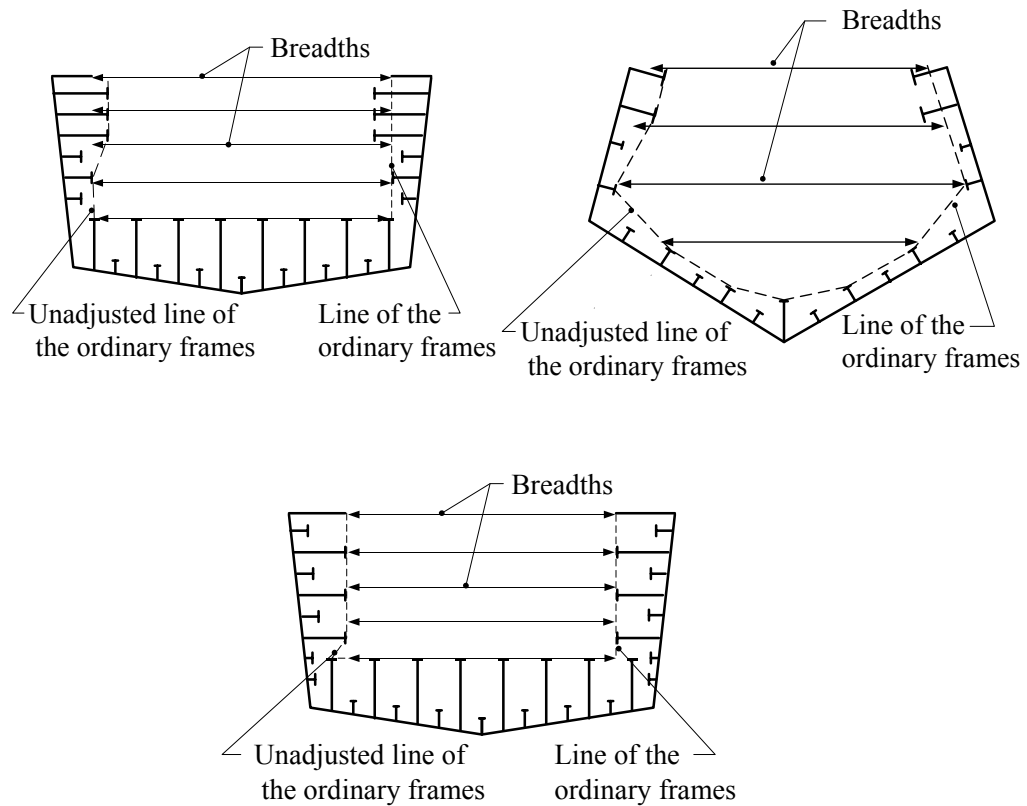

(viii) *Examples* The following examples illustrate the application of the requirements of this section for situations involving longitudinal framing systems with different depths of web. All cases assume: 1) the tonnage section shown is situated in a parallel midbody, where the framing continues without interruption or change for the length of a tonnage interval; 2) the spacing between the bottom and side frames frames is 4 feet or less; 3) the vessel's midpoint depth is 16 feet or less, so there are five breadth measurements and not seven.

Example 1

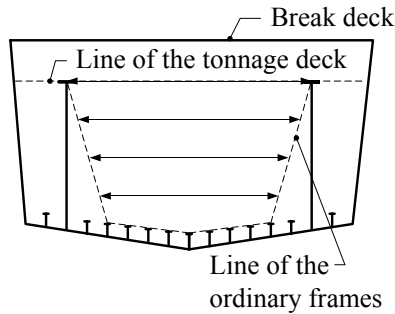

Example 5

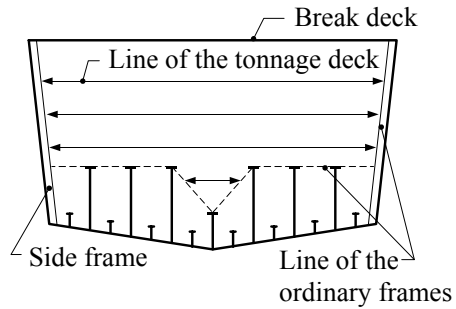

Example 2

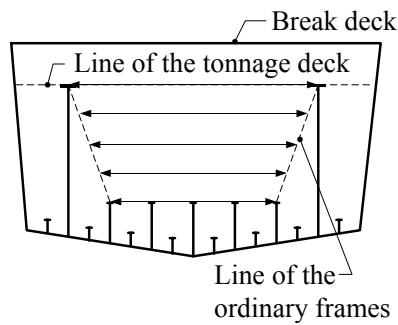

Example 6

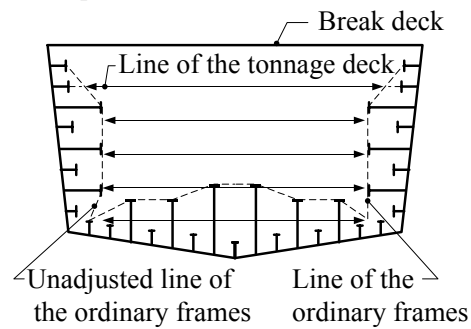

Example 3

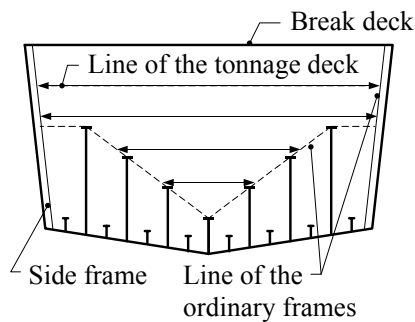

Example 7

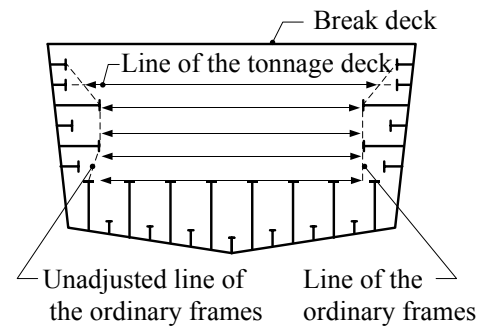

Example 4

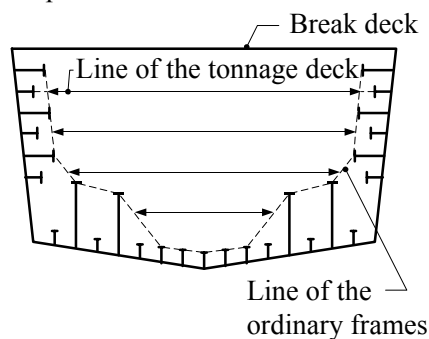

(4) **Bottom Floors and Framing** To qualify as ordinary bottom floors or frames, the frame must be attached to the bottom skin of the vessel inboard of the turn of bilge, and meet all the requirements of ordinary transverse or longitudinal framing. In addition, the following requirements apply:

(i) General The lower terminus of the tonnage depth must coincide with the vertical location where the inboard face of the bottom floors or frames is the lowest. The lowest breadth measurement is taken horizontally at that location.

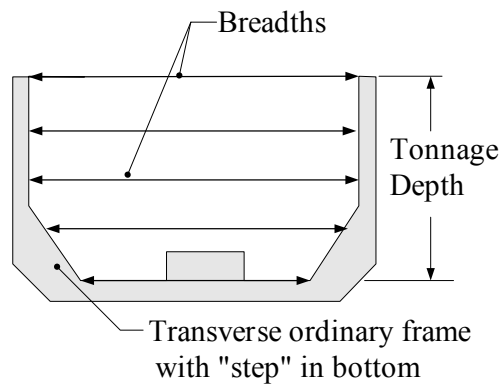

(ii) Longitudinal Floors and Frames In the case of ordinary longitudinal bottom floors or frames, the frames need only run continuously side to side (i.e., turn of bilge to turn of bilge); in other words, the frames need not continue up the sides of the vessel

(iii) Transverse Floors and Frames Ordinary transverse bottom floors or frames must attach to ordinary side frames, if the vessel is fitted with ordinary side frames.

(5) **Asymmetrical Framing** Where ordinary frames are asymmetrical about the centerline of the vessel, breadth measurements are determined by taking half-breadths on the side of the vessel that will yield the greatest area for the respective half of the vessel at that station, and multiplying those half-breadths by a factor of two to yield the full breadths.

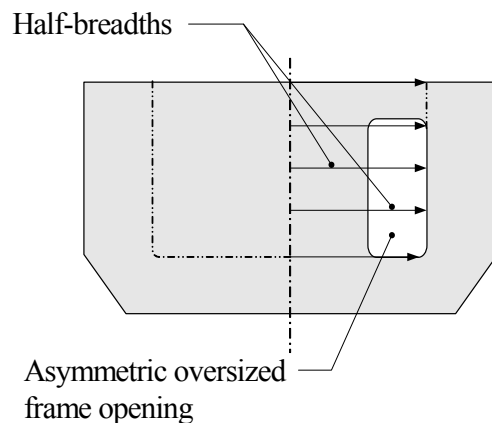
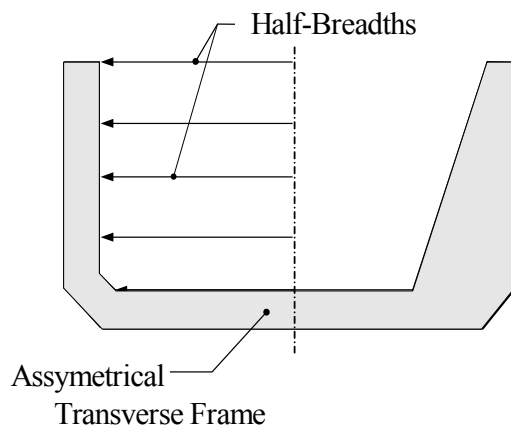

(q) ORDINARY FRAMES IN MULTIHULL VESSELS

These section provides the procedure to be used for establishing the line of the ordinary frames in multihull vessels.

- (1) Establishing Tonnage Deck** *Establish the tonnage deck using the same criteria as provided in §69.109(d). For the deck to be considered a complete deck, it must extend from stem to stern and side to side of the vessel. In this context, the watertight bottom skin (or “wet deck”) between hulls may be considered as part of a “complete” deck, provided the deck “continues” from stem to stern and side to side of the vessel.*

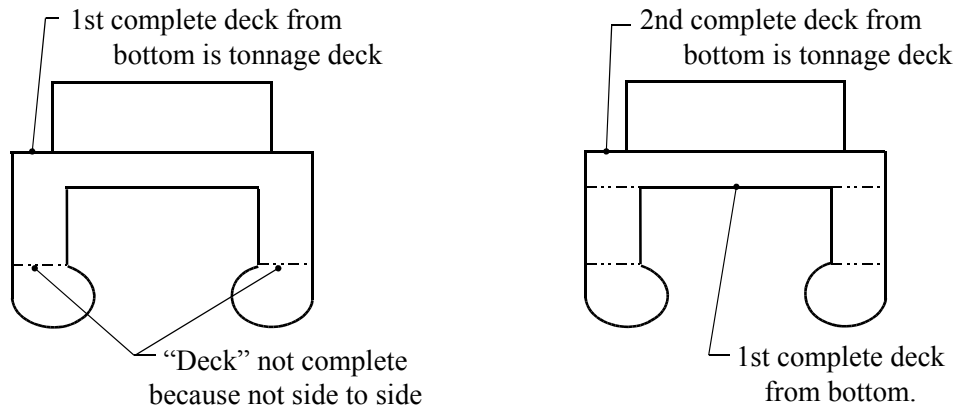

- (2) Establishing Tonnage Length** *The tonnage length is the distance between two planes that are perpendicular to the longitudinal axis of the vessel and tangent to the imaginary surface bounding the inboard faces of the ordinary frames at the extreme fore and aft locations of this surface.*

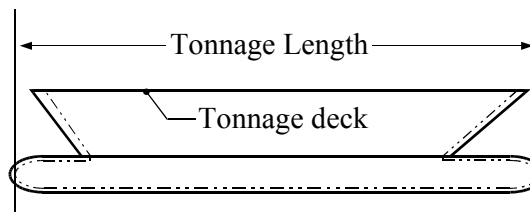

- (3) Establishing Transverse Sections** *Once the tonnage length is established, the vessel is divided into transverse sections using the method of §69.109(g).*

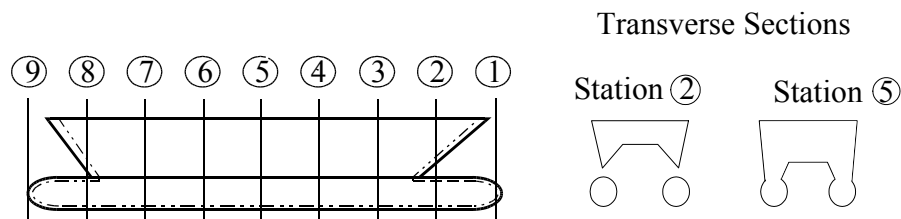

- (4) Identifying Ordinary Frames** *These frames are identified in the same manner as for monohulls. The same restrictions apply for establishing which framing qualifies as ordinary framing as apply to monohulls. For example:*

- (i) *Frames must be spaced on centers that are a maximum of four (4) feet apart across an associated tonnage interval.*
- (ii) *If there are different sized frames, the largest sized frames that alternate with smaller frames and are spaced on centers that are a maximum of eight (8) feet apart across an associated tonnage interval are considered the ordinary frames.*
- (iii) *Frames must be continuous from the bottom of the vessel to the tonnage deck.*

If no framing across an associated tonnage interval qualifies, the line of the ordinary frames is taken at the inner surface of the hull shell for the tonnage station of interest.

- (5) Establishing Unadjusted Line of the Ordinary Frames** *The unadjusted line of the ordinary frames is defined as the line of intersection of: 1) the imaginary surface that is tangent to the inboard faces of the ordinary frames; and 2) the imaginary plane running transversely through the vessel at the tonnage station of interest.*

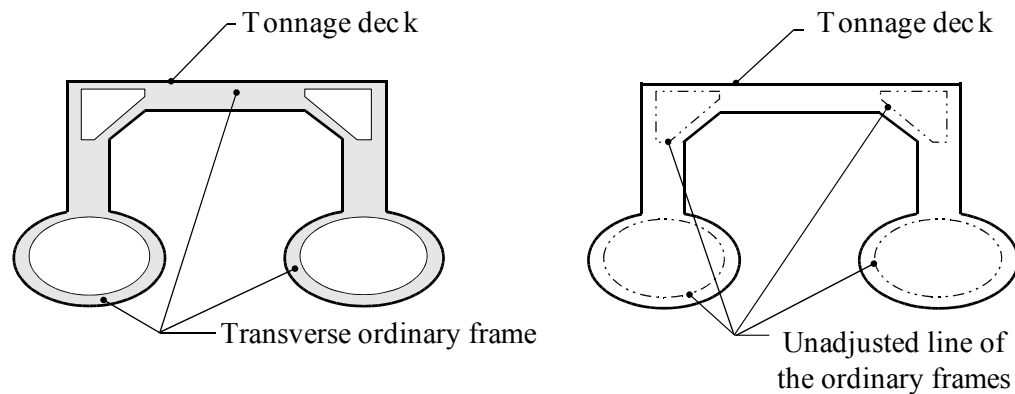

- (6) Establishing the Line of the Ordinary Frames** *The following method is used to establish the line of the ordinary frames at each tonnage station, to which breadth measurements are taken. Note that this process is applied only to the outboardmost portions of the hull.*

- (i) *Establish “offset adjustments” along the outboard sides of the hull(s). “Offset adjustments” are the series of measurements taken between the inner surface of the hull shell and the unadjusted line of the ordinary frames, in a direction perpendicular to the inner hull shell surface.*

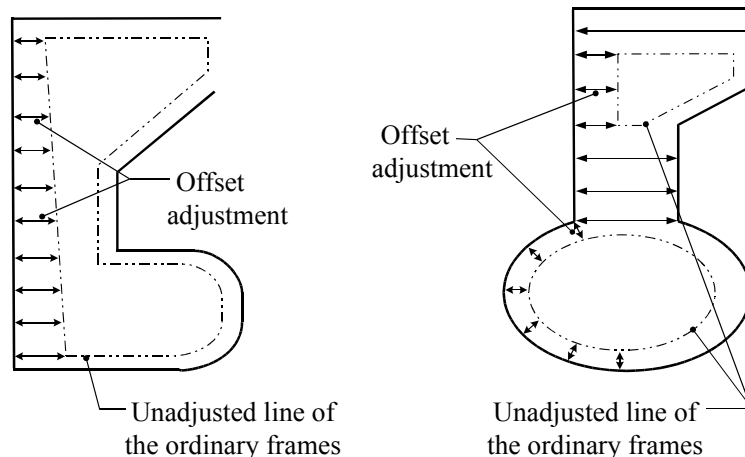

(ii) If the “offset adjustments” remain the same or decrease in length going from the vessel bottom to the tonnage deck, then the line of the ordinary frames is taken at the inboard terminus of the offset adjustments.

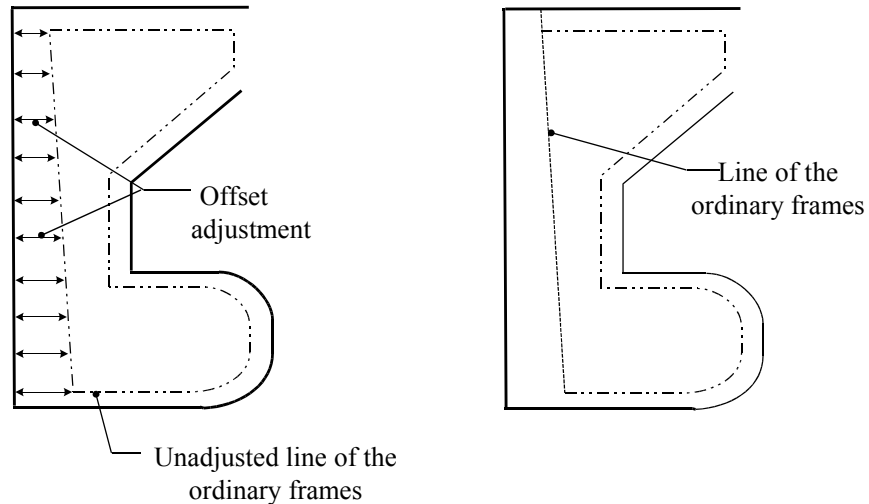

(iii) If the “offset adjustments” increase in length at any point going from the vessel bottom to the tonnage deck, the line of the ordinary frames is taken at the inboard terminus of the “offset adjustments” until the point where the increase begins. At that point, the line of the ordinary frames must follow the inner surface of the hull shell at a distance not less than the length of the “offset adjustment” at the point where the increase began, until an “offset adjustment” of lesser length is encountered. At that point, the line of the ordinary frames returns to the inboard terminus of the “offset adjustments” until the next increase in “offset adjustment” length is encountered. The process repeats upward to the tonnage deck. The general rule is: the line of the ordinary frames from the vessel bottom to the tonnage deck always follows decreasing “offset adjustments.”

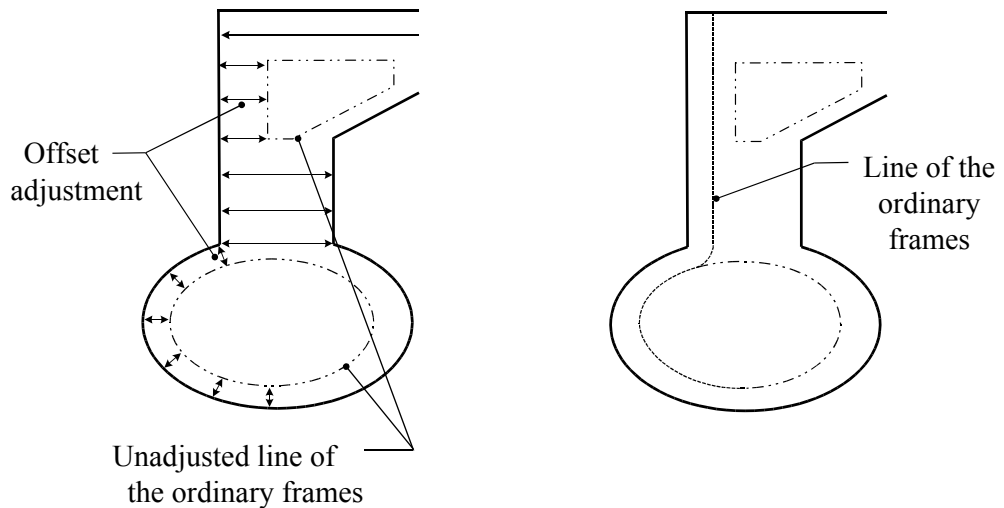

(iv) *Discontinuities in frames (such as notches and larger lightening holes) are treated in a similar manner. Observe the restrictions on frame opening size that apply to monohull vessels.*

(7) **Adjusting Breadth Measurements** *The breadth measurements are adjusted to account only for the enclosed spaces by subtracting out the portion of the breadth measurement outside the hull boundary.*

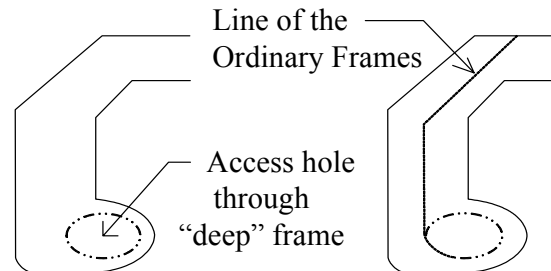

(8) **Treatment of Wet Deck Area** *Breadth measurements may be adjusted using the method of paragraph 7 above to account for that portion of the “cross-deck” or “wet deck” that is open to the sea. If this “wet deck” area is in any way enclosed, it must fully meet the requirements for exclusion as space open to the sea under the convention measurement system in order for the breadth measurements to be adjusted in this manner. Refer to §69.61(f) and (g) for specific requirements (e.g., space cannot be fitted with shelves or other means of securing cargo).*

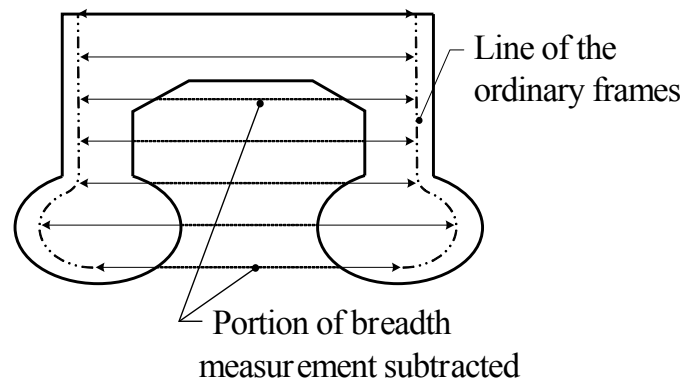

69.111 BETWEEN-DECK TONNAGE

This section provides the method for calculating the between-deck tonnage using Simpson’s first rule. It also provides procedures for establishing the line of the uppermost complete deck.

(a) **BETWEEN-DECK TONNAGE DEFINED**

“Between-deck tonnage” means the tonnage of the space above the line of the tonnage deck and below the line of the uppermost complete deck.

(b) **IDENTIFYING THE LINE OF THE UPPERMOST COMPLETE DECK**

The line of the uppermost complete deck is established as indicated below.

(1) **Deck Runs in Continuous Line** *If the uppermost complete deck runs in a continuous line from stem to stern, the line of the uppermost complete deck is the longitudinal line of the underside of the uppermost complete deck.*

(2) **Deck Runs at Different Levels** If the uppermost complete deck runs at different levels from stem to stern, the line of the uppermost complete deck is the longitudinal line of the underside of the lowest portion of that deck parallel with the upper portion of that deck. Spaces between the line of the uppermost complete deck and the higher portions of the deck are included in superstructure tonnage.

(c) **METHOD OF CALCULATING TONNAGE**

The tonnage of each level of the between-deck space is calculated separately, as follows. *All longitudinal and transverse measurements used to establish between-deck tonnage are terminated at the line of the normal frames.*

(1) **Determine Length** The length of each level is measured at the mid-height between the line of the deck above and the line of the deck below. Measure from the point forward where the continuation of the line of the inboard face of the normal side frames intersects the center line of the vessel aft to the forward face of the normal transom framing.

(2) **Establish Measurement Spacing** Divide the length *determined* under paragraph (c)(1) of this section into the same number of equal parts into which the tonnage length is divided under §69.109(g)(1).

(3) **Measure and Number Breadths** Measure at mid-height between the faces of the normal side frames the inside breadth of the spaces at each end and at each point of division of the length. Number the breadths successively “1”, “2”, and so forth beginning at the bow.

(4) **Apply Simpson’s Multipliers** Multiply the even numbered breadths by four and the odd numbered by two, except the first and last *breadth*, which are multiplied by one.

(5) **Determine Area at Mid-Height** Add together the products under paragraph (c)(4) of this section and multiply the sum by one-third of the interval between the points at which the breadths are taken. The product is the square foot area of the space at mid-height.

(6) **Convert to Tonnage** Multiply the area of the space at mid-height by the average of the heights taken at each point of division of the space. The product divided by 100 is the tonnage of that space.

(7) **Combine the Tonnage of Each Level** The between-deck tonnage is the sum of the tonnage of each level within the between-deck space.

69.113 SUPERSTRUCTURE TONNAGE

This section provides the method for calculating the tonnage of all superstructures.

(a) **SUPERSTRUCTURE TONNAGE DEFINED**

“Superstructure tonnage” means the tonnage of all permanent structures, such as forecastle, bridge, poop, deckhouse, and break, on or above the line of the uppermost complete deck (or line of shelter deck, if applicable).

(b) **METHOD OF CALCULATING TONNAGE**

All longitudinal and transverse measurements used to establish superstructure tonnage are terminated at the line of the normal framing. The tonnage of all structures on each level on or above the uppermost complete deck (or shelter deck, if applicable) is calculated separately as follows: *This*

method applies to structures that are not of standard geometric shape, such as a forecastle that is faired into a non-rectangular hull form.

- (1) **Determine Length** The length of each structure is measured along its centerline at mid-height between the line of the inboard face of the *normal* framing on one end to the line of the inboard face of the *normal* framing on the other end. (See §69.123, figure 11.)
 - (2) **Establish Measurement Spacing** Divide the length *determined* under paragraph (b)(1) of this section into an even number of equal parts most nearly equal to those into which the tonnage length is divided under §69.109.
 - (3) **Measure and Number Breadths** Measure at mid-height the inside breadth at each end and at each point of division of the length. Number the breadths successively “1”, “2”, and so forth beginning at the extreme forward end of the structure. If an end of the structure is in the form of a continuous arc or curve, the breadth at that end is one-half the nearest breadth. If an end is in the form of an arc or curve having a decided flat, the breadth at the end is two-thirds of the nearest breadth.
 - (4) **Apply Simpson’s Multipliers** Multiply the even numbered breadths by four and the odd numbered by two, except the first and last breadth, which are multiplied by one.
 - (5) **Determine Area at Mid-Height** Add together the products under paragraph (b)(4) of this section and multiply the sum by one-third of the interval between the points at which the breadths are taken. The product is the square foot area of the structure at mid-height.
 - (6) **Convert to Tonnage** Multiply this area by the average of the heights taken at each point of the division of the structure between its decks or the line of its decks. The product divided by 100 is the tonnage of that structure.
- (c) **TREATMENT OF STEPPED DECK/SIDES**
A structure having steps in its deck or side must be measured in parts.
- (d) **COMPUTING SUPERSTRUCTURE TONNAGE**
The superstructure tonnage is the sum of the tonnages of each level above the line of the uppermost complete deck (or shelter deck, if applicable).
- (e) **TREATMENT OF SPACES OPEN TO UNDER-DECK**
When a superstructure is located over a cut-away portion of the tonnage deck, the structure’s height is measured from the under side of its overhead deck to the line of the tonnage deck. If the tonnage deck has no camber, allow for camber in the overhead deck.
- (f) **METHOD OF CALCULATING TONNAGE (STANDARD SHAPES)**
For structures of a standard geometric shape, a simple geometric formula that yields an accurate volume may be used.

69.115 EXCESS HATCHWAY TONNAGE

69.117 Spaces Exempt From Inclusion in Gross Tonnage**(a) APPLICABILITY**

Hatchways that are above the tonnage deck and are either open to the weather or within open structures are measured to determine excess hatchway tonnage. Hatchways that are in between-deck spaces, on decks within closed-in structures, or on open structures are not measured.

(b) METHOD OF CALCULATING TONNAGE

The tonnage of a hatchway is its length times breadth times mean depth divided by 100. Mean depth is measured from the under side of the hatch cover to the top of the deck beam.

(c) DETERMINING EXCESS HATCHWAY TONNAGE

From the sum of the tonnage of the hatchways under this section, subtract one-half of one percent of the vessel's gross tonnage exclusive of the hatchway tonnage. The remainder is added as excess hatchway tonnage in calculating gross tonnage.

69.117 SPACES EXEMPT FROM INCLUSION IN GROSS TONNAGE**(a) PURPOSE**

This section lists spaces which are exempt from inclusion in gross tonnage.

(b) SPACES ON OR ABOVE THE LINE OF THE UPPERMOST COMPLETE DECK

The following spaces or portions of spaces on or above the line of the uppermost complete deck are exempt *from inclusion in gross tonnage* if the spaces or portions are reasonable in extent and adapted and used exclusively for the purpose indicated:

- (1) Anchor Gear** Spaces for anchor gear, including capstan, windlass, and chain locker, are exempt.
- (2) Companions** Companions and booby-hatches protecting stairways or ladderways leading to spaces below are exempt, whether or not the spaces below are exempt.
- (3) Galley** Galley or other spaces fitted with a range or oven for cooking food to be consumed onboard the vessel are exempt.
- (4) Light or Air** Spaces designed to provide light or air to propelling machinery are exempt, as follows:
 - (i) When propelling machinery is located entirely on or above the line of the uppermost complete deck, the entire propelling machinery space and all fuel bunker spaces that are also located above that line are exempt as light or air spaces. (See exceptions in §69.121(d)(1) for framed-in spaces.)
 - (ii) When part of the propelling machinery projects above the line of the uppermost complete deck into a space used exclusively to provide light or air to the propelling machinery, the entire space is exempt as light or air space. When any portion of this space is used for purposes other than providing light or air, only the portion of the space used for light or air, the space occupied by the propelling machinery itself, and a propelling machinery working space allowance under §69.121 limited to two feet, if available, on each side of the propelling machinery are exempt.
 - (iii) Any part of an escape shaft, or a companion sheltering an escape shaft, above the line of the uppermost complete deck is exempt as light or air space.

- (iv) Space that would otherwise be exempt as a light or air space is not exempt when propelling machinery is boxed-in and does not extend above the line of the uppermost complete deck. Any portion of the boxed-in space above the line of the uppermost complete deck is exempt.
- (5) **Skylights** Skylights affording light or air to a space below, other than to propelling machinery spaces. Space immediately below the line of the deck on which a skylight is located is exempt only when there is an opening in the next lower deck directly below the skylight to permit light or air to an even lower deck.
- (6) **Machinery Spaces** Machinery spaces, other than for propelling machinery under §69.121
- (7) **Steering Gear** Spaces for steering gear.
- (8) **Water Closets** Water closet spaces that are fitted with at least a toilet and are intended for use by more than one person. *In this context, “use by more than one person” means “use by more than one specific individual”, rather than “use by more than one person simultaneously.” Areas within a water closet space that are occupied by showers and sinks may be exempted as part of the associated water closet space.*
- (9) **Wheelhouse** The space in a wheelhouse necessary for controlling the vessel.
- (c) **PASSENGER SPACES**
- (1) **Passengers on Military Vessels** As used in this section, the term “passenger” includes officers and enlisted men on military vessels who are not assigned ship’s duties and not entered on the ship’s articles.
- (2) **Definition of Passenger Space** As used in this section, “passenger space” means a space reserved exclusively for the use of passengers and includes, but is not limited to, berthing areas, staterooms, bathrooms, toilets, libraries, writing rooms, lounges, dining rooms, saloons, smoking rooms, and recreational rooms. The space need not be part of or adjacent to a berthing area to be considered a passenger space.
- (3) **Restrictions on Location** A passenger space located on or above the first deck above the uppermost complete deck is exempt from gross tonnage.
- (4) **Exemption as Open Space** ~~A passenger space located on the uppermost complete deck is exempt from gross tonnage only when it has no berthing accommodations and is an open structure under paragraph (d) of this section.~~ *The prohibition against exempting a passenger berthing space as open space is in error, as it conflicts with language contained in the underlying statute and is inconsistent with the principles of “open structures” as set forth in the regulations. Removal of this prohibition from the regulations will be addressed in a future rulemaking.*

(d) OPEN STRUCTURES

- (1) **General** Structures that are located on or above the line of the uppermost complete deck that are under cover (sheltered), but open to the weather are exempt from gross tonnage. *If a structure is divided into compartments, only those compartments which are open to weather as provided for in §69.117(d)(2),(2'),(3),(7) and (8) are exempt from gross tonnage under the provisions of this regulation. Also, open space cannot progress from one structure into another structure (e.g., from a sunken forecastle to a break aft of the forecastle), nor can it progress vertically through openings in a deck within the structure.*

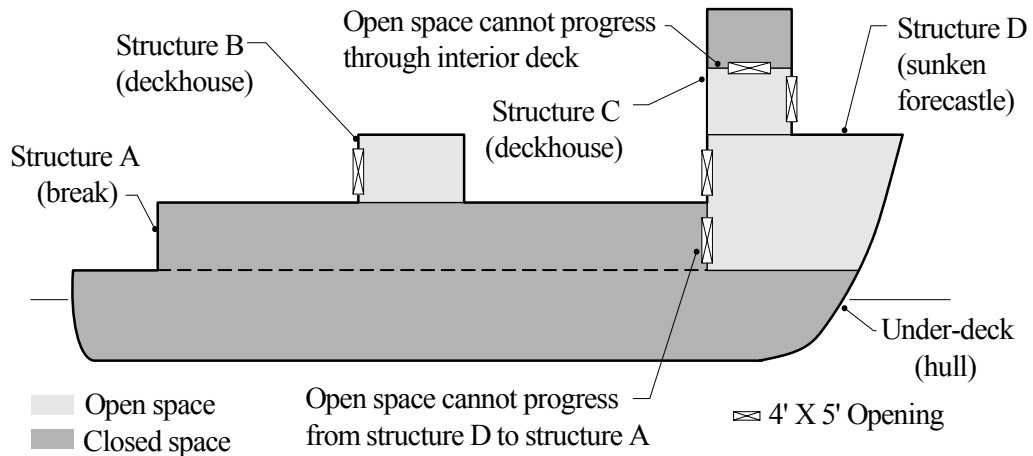

- (2) **End Openings** A structure is considered "open to the weather" under paragraph (d)(1) of this section when an exterior end bulkhead of the structure is open and, except as provided in paragraphs (d)(4), (d)(5), and (d)(6) of this section, is not fitted with any means of closing. To be considered "open to the weather", the end bulkhead must not have a coaming height of more than two feet in way of any required opening *as measured to the deck outside the opening*, and have one of the following openings or combinations of openings. *Except as provided for in §69.117(d)(3), if the structure has more than one compartment, only that portion of a compartment with an exterior opening or openings meeting the requirements of this section and whose deck is no more than two feet above the associated exterior deck at the end opening(s), is considered "open to weather".*

- (i) Two 3' X 4' Openings Two openings, each at least three feet wide and at least four feet high in the clear on each side of the centerline of the structure. *If the openings lead to two separate interior compartments, there must be circulation of open space between the two compartments via an opening (or series of openings) in the intermediate bulkhead(s) meeting the minimum requirements of this section for a 3' X 4' opening. If such circulation does not exist, both openings are considered closed.*

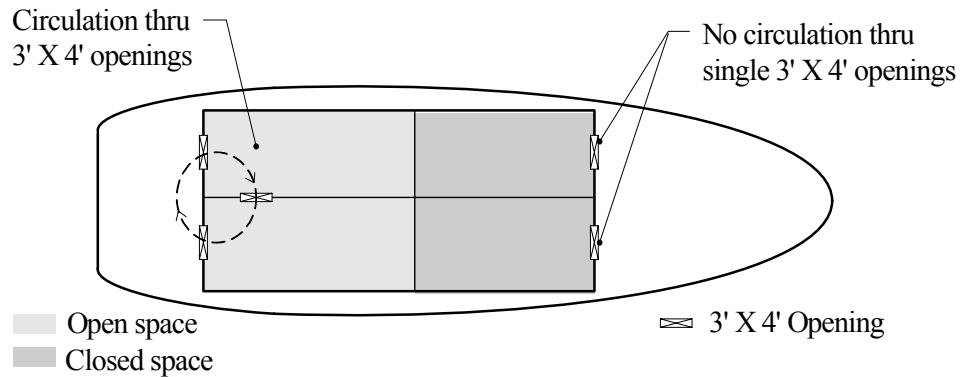

- (ii) One 4' X 5' Opening One opening at least four feet wide and at least five feet high in the clear.

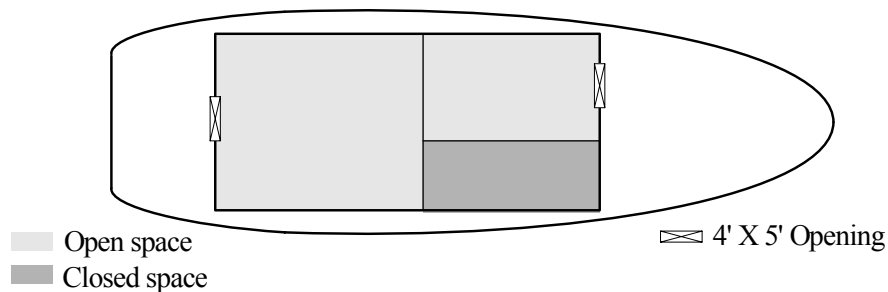

- (iii) One Equivalent Opening One opening at least 20 square feet in the clear with a breadth in excess of four feet and a height of not less than three feet.

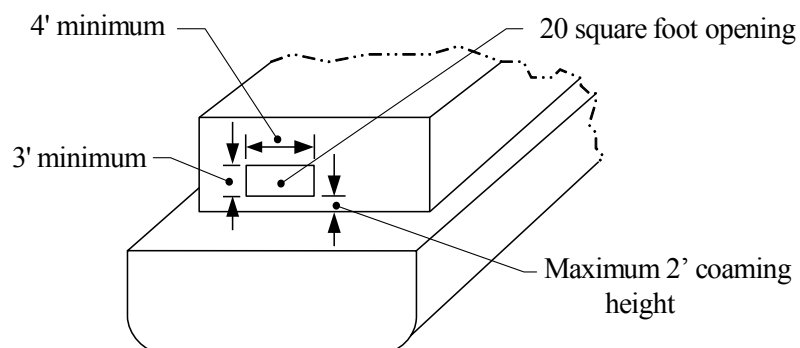

- (2') Additional Requirements for End Openings In addition to the requirements of §69.117(d)(2), the following requirements apply to end openings:

(i) *In the Clear Requirement* To be considered in the clear as described in §69.117(d)(2), the opening must be unobstructed for a distance of 30 inches both inside and outside of the opening. Obstructions of a temporary nature (i.e., that are not permanently attached to the vessel, can readily be removed underway, and whose removal does not adversely impact the safe operation of the vessel) are not considered to violate the in the clear requirement. For example, portable furniture and lockers are considered to be of a temporary nature, whereas bulkheads, stanchions, bunks that are part of joiner work, and handrails are not. In all cases, attachments to temporary covers authorized under §69.117(d)(6') and deck cargo are not considered to violate the in the clear requirement.

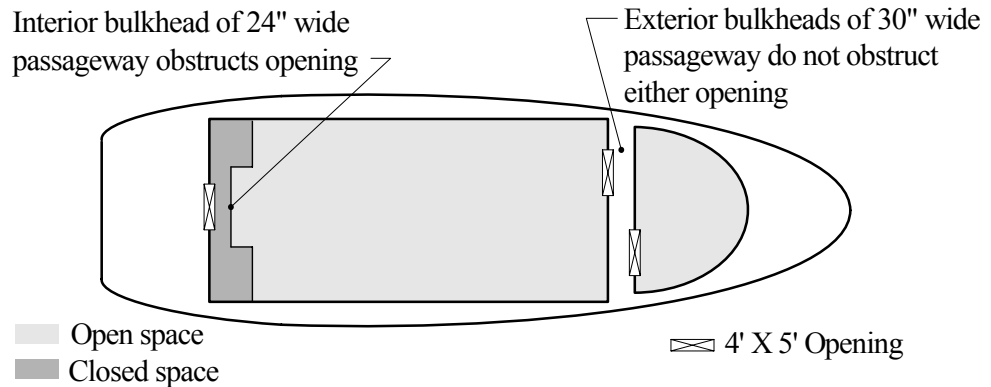

(ii) *Minimum Opening Dimensions* Minimum opening dimensions must be maintained throughout the entire width and height of the opening. For example, coamings, shifting board channel sections, and rounded corners must not infringe on minimum width and height requirements of the opening.

(iii) *Progression of Open Space Within the Structure:* Open space is considered to progress from openings meeting the minimum requirements of this section throughout the associated interior compartment. Obstructions within the compartment (e.g., passenger seating, stanchions, false ceilings, handrails and furniture) are not considered to interfere with the progression of open space within the same compartment, whether or not the obstructions are temporary in nature. However, such obstructions installed within 30 inches of an end bulkhead opening could cause the entire compartment to be treated as closed, depending on whether or not the obstruction is temporary in nature as described in §69.117(d)(2')(i).

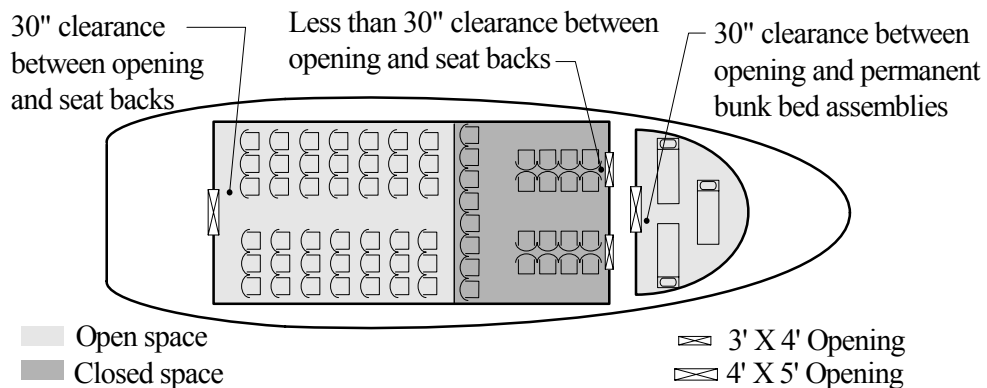

- (iv) Angled or Curved Bulkheads To qualify as an end bulkhead, the portion of the bulkhead in way of a qualifying opening must not be oriented any greater than 45 degrees from the horizontal or athwartship planes. Width, height and area requirements for openings in angled or curved end bulkheads are applied to the longitudinal projection of the opening onto a vertical athwartship plane at the opening.

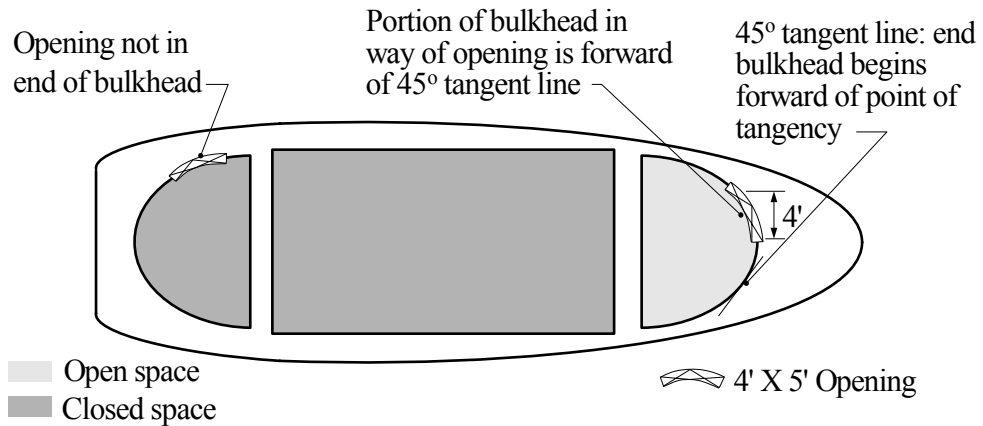

- (v) Deck or Platform on Exterior Side of Opening There must be a permanent deck or platform that is a minimum of 30 inches wide on the exterior side of the opening. The deck or platform can either be solid or a grating. It must extend at least the full width of the opening, and be no more than 2 feet below the bottom edge of the opening.

- (3) **Open Space Progression to Interior Compartments** A compartment within an open structure is considered open to the weather only when an interior bulkhead of that compartment has an opening or openings that meet the requirements for end bulkheads under paragraphs (d)(2)(i) through (d)(2)(iii) of this section, and the deck of that compartment is no more than two feet above the associated exterior deck at the end opening(s). Other compartments within the structure are not considered open to the weather. The following additional requirements apply:

- (i) Establishing Compartment Boundaries: In this context, a compartment is defined as a space within an open structure that is bounded by bulkheads and the deck above and below. Passageways and dead-ended recesses are considered to be part of the larger compartment to which they are connected, until such point that the passageway and/or dead-ended space increases in height or width, beyond which point the space is considered to be a separate compartment. For situations where one boundary of a compartment is not clearly defined (e.g., a situation involving corners), the "projected" boundary that delineates the compartment is taken as the continuation of the bulkhead of the compartment from which open space is progressing.

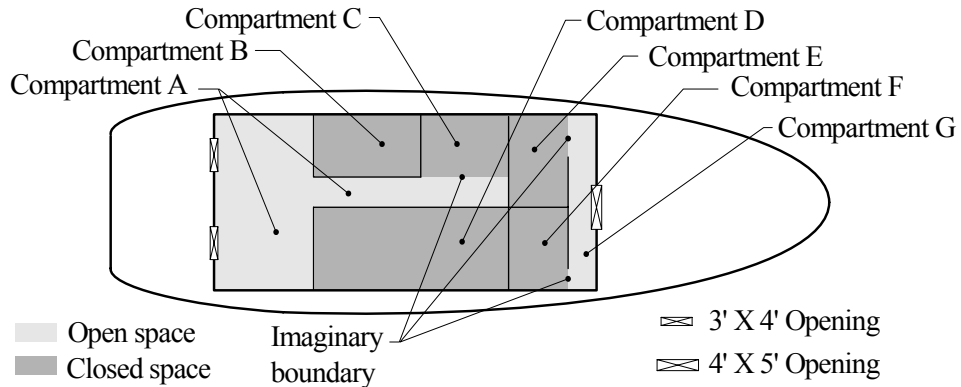

- (ii) Progression of Open Space From Other Interior Compartments: For the interior compartment to be treated as open, the compartment (or series of compartments) from which open space progresses must have opening(s) that meet the requirements for end bulkhead openings under §69.117(d)(2) and (2'). In addition, the following applies:

- (1) Opening Location Openings that otherwise meet the requirements of §69.117(d)(2) may be installed in longitudinal as well as transverse interior bulkheads, and may be located anywhere along the bulkhead.

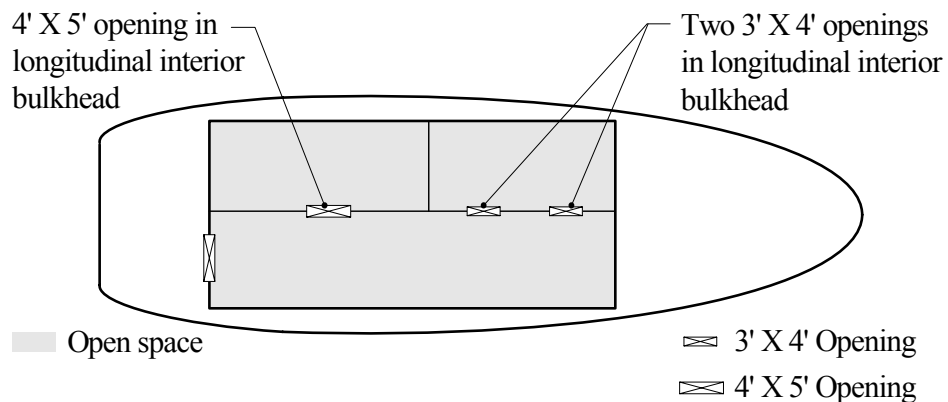

(2) Circulation Requirement The circulation requirement of §69.117(d)(2)(i) must be met for all interior bulkhead 3' X 4' openings:

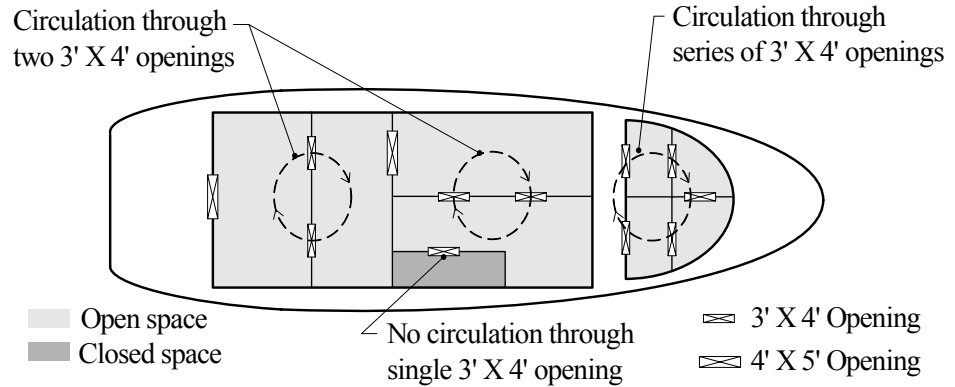

(3) Obstructions to Interior Bulkhead Openings The in the clear requirement of §69.117(d)(2')(i) must be met for all interior bulkhead openings. As discussed in §69.117(d)(2')(iii), obstructions within a compartment that are not within 30 inches of an opening do not affect progression of open space.

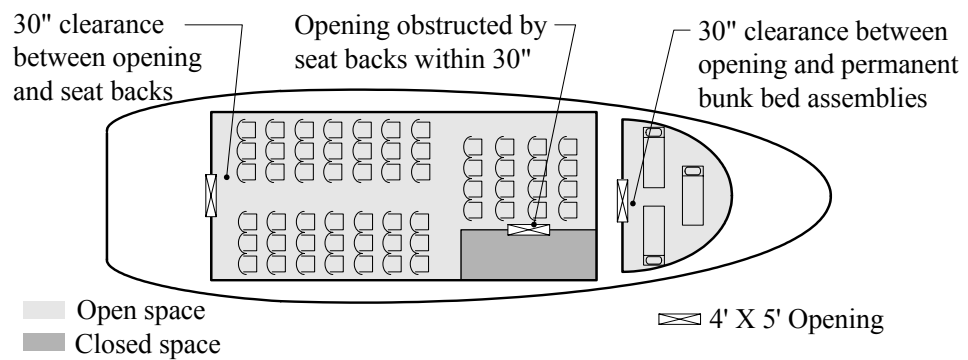

- (4) Obstructions for Openings Where Boundary Not Clearly Defined In situations where the boundary of an interior compartment is not clearly defined, the 30 inch in the clear requirement of §69.117(d)(2')(i) is applied to an "opening" in the projected boundary established in §69.117(d)(3)(i).

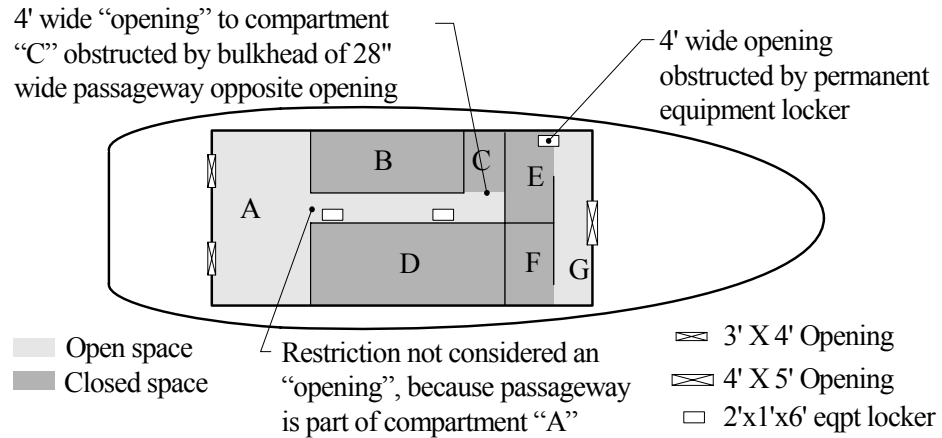

- (5) Temporary Covers for Openings In applying the requirements of §69.117(d)(4),(5) and (6) to interior bulkhead openings, the weather side of the bulkhead is considered to be the side toward the associated exterior end bulkhead opening from the direction that the open space is progressing. In the case of 3' X 4' openings used to progress space from two different compartments, the temporary cover can be on either side of the compartment bulkhead.
- (6) Propelling Machinery Space Bulkheads There is no longer a prohibition against progression of open space through a propelling machinery space bulkhead.
- (iii) Treatment of Bars and Similar Subspaces Partitions used to partially bound bars, serving areas, and similar subspaces within a larger compartment are not considered to be a bulkhead that subdivides the associated space into a separate compartment, provided the partition has an opening or openings into the surrounding compartment without means of closure that meet(s) the following criteria:
- (1) Opening height is at least one-third of the height of the larger compartment.
 - (2) Bottom of opening is no more than 42 inches above the deck of the larger compartment at the opening.
 - (3) Opening is in the clear as described §69.117(d)(2')(i), except for the stanchions (or equivalent) necessary for the support of the deck above.
 - (4) For subspaces with only one side open to the larger compartment, the opening must extend the full width or length of the larger compartment. For all other subspaces, at least two sides of the subspace must be open to the larger compartment as described in this section, with each opening extending the full width or length of the respective side.

- (4) **Shifting Boards in Channels** An interior or exterior opening that is temporarily closed by shifting boards dropped into channel sections at the sides of the opening is considered open to the weather if battening, caulking, *seals*, or gaskets of any material are not used.
- (5) **Plates/Boards With Hook Bolts** An interior or exterior opening that is temporarily closed by cover plates or boards held in place only by hook bolts is considered open to the weather –
- (i) **Hook Bolts** If hook bolts, “J” bolts, or “L” bolts used to secure cover plates or boards are spaced at least one foot apart and hook over a stiffener installed around the perimeter of the opening;
 - (ii) **Faying** If the cover plates or boards fit tightly against the *weather side of the* bulkhead; and
 - (iii) **Sealing** If battening, caulking, *seals* or gaskets of any material are not used.

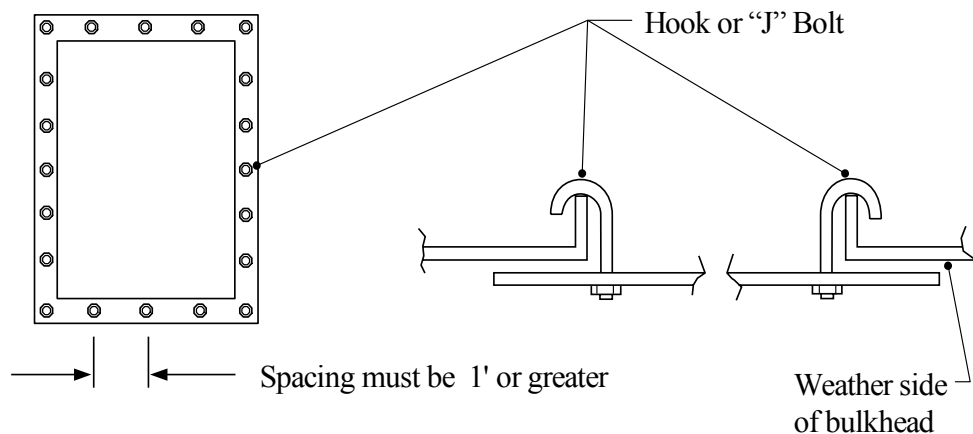

- (6) **Plates/Boards With Bolts and Crosspieces** An interior or exterior opening that is temporarily closed by cover plates or boards held in place only by bolts and crosspieces (*i.e.*, “strongbacks”) is considered open to the weather –
- (i) **Bolts** If the bolts are not installed through the bulkhead. *There are no requirements on bolt spacing;*
 - (ii) **Securing Devices** If the bolts and crosspieces are not held in place by cleats or other attachments to or through the bulkhead;
 - (iii) **Faying** If the cover plates or boards fit tightly against the *weather side of the* bulkhead; and
 - (iv) **Sealing** If battening, caulking, *seals* or gaskets of any material are not used.

- (v) Plates as Crosspieces There is nothing to preclude the use of a single backing plate or board covering the inside of the opening as a crosspiece (a so-called "sandwich" construction).

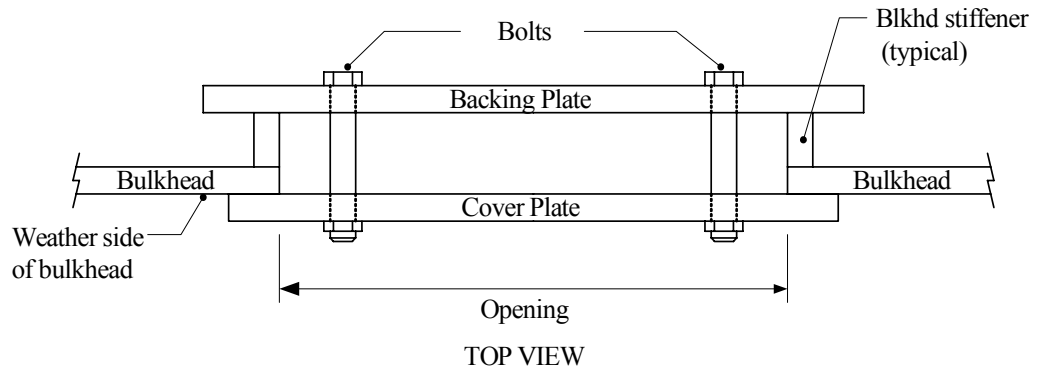

- (6) **Additional Requirements for Temporary Covers** The following additional requirements apply to temporary covers described in §69.117(d)(4),(5) and (6):

- (i) Cover Boards and Plates Each plate or board may be composed of more than one element, which may be of different materials, though the individual elements of each plate or board must be permanently bonded together to form an integral unit. For example, trim strips on the outer edges of a cover plate must be permanently bonded to the plate in order to be considered a continuation of that plate.
- (ii) Attachments and Penetrations Anything affixed to, or installed in, a temporary cover (e.g., paneling, bulkhead "plugs", insulation, doors, windows, fans, air conditioners, fire hoses, and cover plate plugs) must not: 1) be affixed to the adjoining bulkhead; 2) in any way hinder the removal of the cover; and 3) overlap the edges of the opening in any manner so as to make the cover more than non-tight. For example, a solid piece of insulation overlapping the edges of a cover plate would render the opening closed, whereas electrical equipment mounted on a cover plate but plugged into a wall receptacle on the bulkhead would not.

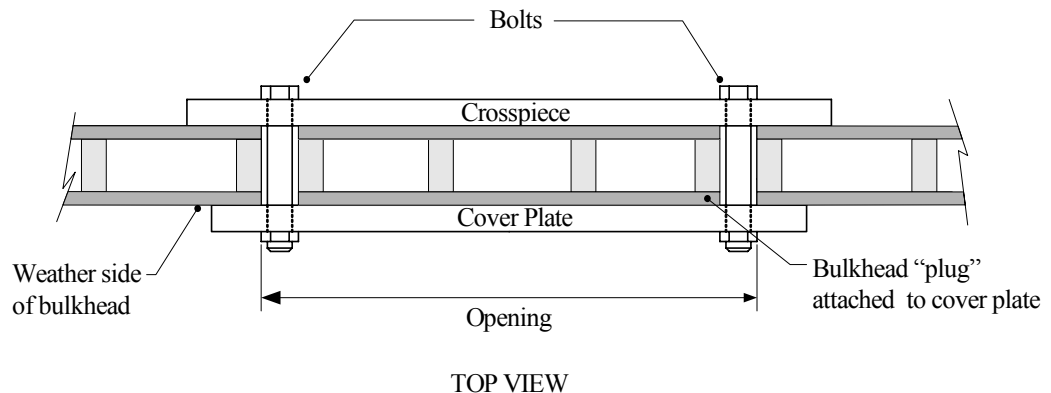

- (iii) Cover Fasteners Fasteners used to hold cover plate(s) or board(s) in place must be designed such that removal of the fasteners causes the associated plates(s) or board(s) to "fall free". The fasteners must be completely accessible to the extent that the plate can be readily removable at all times; otherwise, the associated opening is considered closed. Anything used to "hide" the portions of the fasteners to which access is required must be temporary in nature as defined in §69.117(d)(3')(i), and must be attached only to the cover plate(s), board(s) or crosspiece(s).

(v) Alternate Covers In addition to the temporary covers described in §69.117(d)(4), (5) and (6), wire mesh or a flexible fabric-like material (such as canvas) may be applied to an otherwise uncovered opening without closing the opening. Framing, cleats, battens or cross braces, if used to secure the wire mesh or fabric, must not interfere with the in the clear requirement for the opening as described in §69.117(d)(2')(i). **NOTE: No other alternate covers are authorized. This includes sliding doors, hinged doors, and expandable partitions installed across otherwise qualifying openings, even if the item clears the opening when in the open position and/or can be easily removed.**

(vi) Impact on Vessel Safety As is the case with other tonnage reduction features, it is the responsibility of the designer/owner/operator to ensure that safety aspects of temporary covers are carefully evaluated. For example, an opening cannot be made to be watertight using temporary covers described in §69.117(d)(4), (5) or (6) and, therefore, could compromise a vessel's watertight integrity. For fire protection of temporary covers, refer to the requirements of Navigation and Vessel Inspection Circular (NVIC) 9-97, Guide to Structural Fire Protection.

(7) Structures Entirely Open From Aft End Notwithstanding the opening size requirements of §69.117(d)(2), a structure with its aft end entirely open from the under side of its overhead stiffeners down to the deck, to the line of the deck, or to a coaming not exceeding three inches in height and open athwartships between the inboard faces of the side stiffeners is considered open to weather. The opening may be covered by a wire mesh screen or temporarily closed by a flexible fabric-like material (such as canvas) secured at the top and lashed or buttoned in place. Open space may progress from a compartment open from the aft end to another compartment, provided the requirements of §69.117(d)(3) for progression of open space within a structure are met.

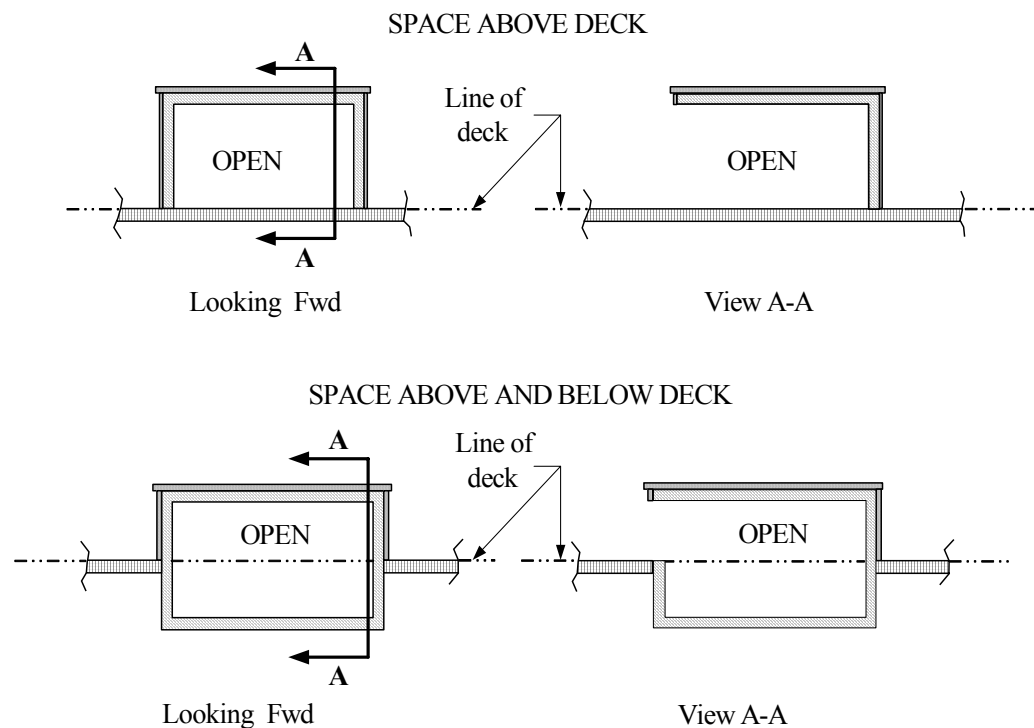

(8) **Opposite Side Openings** A structure is considered "open to the weather" under §69.117(d)(1) if both sides of the structure are open and, except as provided for in §69.117(d)(4),(5) and (6), are not fitted with any means of closing. The following additional requirements apply:

(i) Openings are Opposite and Not Separated by Bulkheads The openings must be directly across from each other, on opposite sides of the structure, and must not be separated by a bulkhead (or bulkheads).

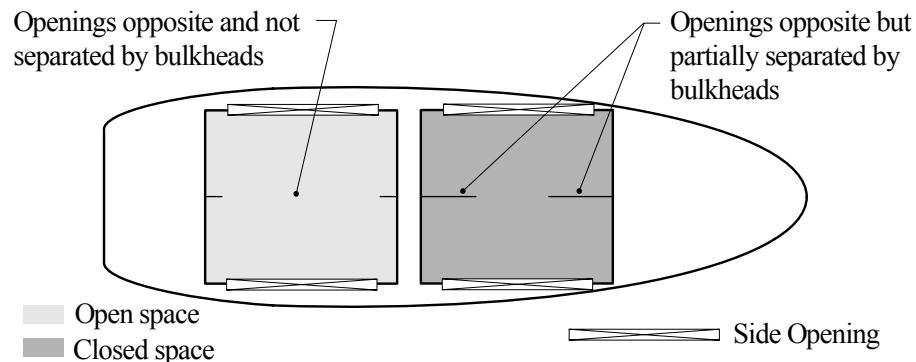

(ii) Opening Size Each opposite side opening or combination of openings must meet the minimum area requirements that follow. When a combination of openings on each side are used to meet minimum area requirements, the openings cannot be separated from the adjacent opening(s) by any more than the stanchions (or equivalent) necessary to support the overhead deck covering. Where a 3 foot minimum height is specified, the minimum height must be maintained throughout the entire length of the opening (e.g., the height cannot be infringed on by rounded corners).

(1) 60 Square Feet and 3 Feet High The opening(s) on each side must have an aggregate area of at least 60 square feet and a continuous height of at least 3 feet.

(2) 60 Square Feet and Full Height The opening(s) on each side must have an aggregate area of at least 60 square feet and must extend the full height of the sides.

(3) Full Length of Structure and 3 Feet High/Full Height The opening(s) on each side must: 1) extend the full length of the sides of the structure; and 2) have a continuous height of at least 3 feet or the full height of the structure, whichever is less.

(iii) Coamings There are no restrictions on coaming heights (if fitted) beneath the openings.

(iv) Progression of Open Space Open space will progress from a compartment open to the weather using opposite side openings to another compartment, provided the requirements of §69.117(d)(3) for progression of open space within a structure are met.

(e) OPEN SPACE BETWEEN THE SHELTER DECK AND THE NEXT LOWER DECK

(1) **General** Space that is between the shelter deck and the next lower deck (by definition, the uppermost complete deck) and that is under cover (sheltered) but open to the weather is exempt

from gross tonnage when all openings in the uppermost complete deck are provided with a watertight means of closing. *Associated scuppers cannot be submerged under any loading condition if open space is to be exempt from gross tonnage under this section.*

- (2) **Requirements for Middle Line Openings** A space is considered “open to the weather” under paragraph (e)(1) of this section when the shelter deck above the space has a middle line opening which conforms to the following:
- (i) **Size and Shape** The middle line opening must be at least four feet long in the clear and at least as wide as the after cargo hatch on the shelter deck, but not less than one-half the width of the vessel at the midpoint of the length of the opening. The opening may have rounded corners not exceeding a nine inch radius. When a greater radius is required by the Coast Guard or a Coast Guard recognized classification society under §42.05-60 of this chapter, notification of that requirement must be submitted to the Commandant (*Marine Safety Center*).
 - (ii) **Longitudinal Position** The middle line opening must be located so that the distance between the aft edge of the middle line opening and the vessel’s stern is not less than one-twentieth of the tonnage length of the vessel and the distance between the fore edge of the opening and the vessel’s stem is not less than one-fifth of the tonnage length of the vessel.
 - (iii) **Enclosing Structures** The middle line opening must not be within a structure of any type.
 - (iv) **Railings and Stanchions** If the middle line opening is guarded by rails or stanchions, the rails and stanchions must not be used to secure or assist in securing a cover over the opening.
 - (v) **Coamings and Covers** The coaming of the middle line opening must not exceed one foot mean height above the shelter deck. Bolts must not pass through the stiffeners or flanges on the coaming, nor may there be any other attachments on the coaming for fastening a cover. Portable wooden covers may be fitted over the middle line opening if held in place only by lashings fitted to the under side of the covers. Metal covers may be fitted if held in place only by hook bolts spaced not less than 18 inches apart that pass through the cover and hook over angle stiffeners or flanges fitted to the outside of the coaming. *Battening, caulking, seals or gaskets of any material may not be used in association with any middle line opening cover.*
 - (vi) **Space Below Opening** The space below the middle line opening must have a minimum length of four feet throughout its entire breadth and height and be in the clear at all times.
 - (vii) **Scupper Requirements** A scupper having a five inch minimum inside diameter and fitted with a screw down non-return valve geared to and operated from the shelter deck must be fitted on each side of the uppermost complete deck in way of the middle line opening.
- (3) **Middle Line Openings and 3 X 4 Foot Tonnage Openings** When the shelter deck space forward or aft of the middle line opening is divided by interior bulkheads, only those compartments with at least two openings that progress to the middle line opening are considered “open to the weather” under paragraph (e)(1) of this section. Each required opening must be at least three feet wide and at least four feet high in the clear, must not have a coaming height of more than two feet, and must not be fitted (except as provided in paragraphs (d)(4), (d)(5) and (d)(6) of this section) with any means of closing. Other compartments within the shelter deck space are not considered “open to the weather” under paragraph (e)(1) of this section.

(f) WATER BALLAST SPACES

A space, regardless of location, adapted only for water ballast and not available for stores, supplies, fuel, or cargo (other than water to be used for underwater drilling, mining, and related purposes, including production), upon request, may be exempt from gross tonnage if the following are met.

- (1) Available Only For Water Ballast** The space must be available at all times only for water ballast that is piped through a system independent of other systems (except fire fighting and bilge suction systems). Pumps, pipes, and other equipment for loading and unloading water ballast must be of a size suitable for the efficient handling of the water ballast within a reasonable time frame.

Manhole Requirements All manholes providing access to a water ballast space must be oval or circular and not greater than 34 inches in diameter. Except for those on a deck exposed to the weather, the manholes may have a coaming not exceeding six inches in height.

Hatch Requirements Existing hatches over spaces being converted to water ballast spaces must have a water tight cover plate welded to the hatch and a manhole, as described in this paragraph, fitted in the plating.

- (2) Purpose of Water Ballast** The primary purpose of the water ballast must be to afford a means of maintaining the vessel's stability, immersion, trim, pre-loading conditions, or seakeeping capabilities.

- (3) Relation to Stability Analysis** If the space is in a vessel that is subject to inspection under 46 U.S.C. 3301, the space must be considered when determining the adequacy of the vessel's stability under 46 CFR chapter I.

- (4) Water Ballast Justifications** If the total of all water ballast spaces to be exempted from gross tonnage exceeds 30% of the vessel's gross tonnage (as calculated under this subpart without any allowance for water ballast), a justification of the operating conditions that require the water ballast must be submitted to the measuring organization for approval. Although a single condition may justify all water ballast spaces, several conditions may be necessary in other cases. However, a particular tank is not justified by a condition if another tank already justified by another condition could be used as effectively. The justification must -

- (i)** Designate the vessel's service;
- (ii)** Explain for what purpose under paragraph (f)(2) of this section the water ballast is being used;
- (iii)** Provide the calculations required in paragraphs (f)(4)(vi) through (f)(4)(ix) of this section for those uses on a form similar to Coast Guard Stability Test Form CG-993-9;
- (iv)** Include the capacity, tank arrangement, and piping plans for the vessel;
- (v)** Include a statement certifying that the space will be used exclusively for water ballast as prescribed by this section;
- (vi)** If water ballast is used for stability, describe each loading condition and the resultant metacentric height (GM) and include calculations;

- (vii) If water ballast is used for immersion or trim, describe those conditions and include loading and trim calculations;
 - (viii) If water ballast is used for preloading, describe how it is used and include strength and weight calculations; and
 - (ix) If water ballast is used for seakeeping, describe each loading condition, GM, period of roll, and, if speed is involved, speed versus trim and draft and include calculations.
- (5) **Reporting of Changes** If the water ballast space or its use, purpose or piping are changed, the vessel owner or operator must report the change promptly to a measurement organization listed in §69.15 for a determination as to whether a tonnage measurement is required. *Changes in vessel service should also be reported if a water ballast justification was required to be submitted for the vessel.*

(g) METHODS FOR MEASURING EXEMPT SPACES

- (1) **Superstructure** If the exempt space is located within the superstructure, the exempt space is measured using the same procedures used to measure superstructure tonnage under §69.113.
- (2) **Between-Deck** If the exempt space is located between-deck, the space is measured using the same procedures used for between-deck tonnage under §69.111(c), except that the length of the exempt space is divided into the even number of spaces most equal to the number of spaces into which the between-deck was divided.
- (3) **Under-Deck** If the exempt space is located under-deck, the spaces is measured using the same procedures used for under-deck tonnage under §69.109, except that the length of the exempt space is divided into the even number of spaces most equal to the number of spaces into which the under-deck was divided. *Use the following procedure to ensure that under-deck water ballast space exemptions reflect only the portions of water ballast spaces that were included in the under-deck volume calculations:*
 - (i) *Develop a plan view or side profile, showing the tank stations and the under-deck tonnage stations.*
 - (ii) *On this plan view or side profile, lay out zones of influence around each under-deck tonnage station. The zones of influence are as follows, depending on the Simpson’s first rule multiplier for the associated underdeck tonnage station:*

<i>Simpson’s Multiplier</i>	<i>Length of Zone of Influence</i>
<i>1</i>	<i>One 1/3 common interval</i>
<i>2</i>	<i>Two 1/3 common intervals</i>
<i>4</i>	<i>Four 1/3 common intervals</i>

- (iii) *For each tank station, identify the under-deck tonnage station under whose “zone of influence” the tanks station falls. In cases where the tank terminates precisely at the*

boundary between two zones of influence, chose the zone of influence that will yield the largest tank sectional area under step (iv) below.

- (iv) Superimpose (project) the outline of each tank section onto the associated under-deck tonnage section at the under-deck tonnage station identified in step (iii) above. Then, for each tank station, calculate the tank sectional area by applying Simpson's first rule to the portion of the tank that is inboard of the line of the ordinary frames of the under-deck section.*
- (v) Perform a longitudinal integration of all tank sectional areas using the tank's "tonnage" length and the sectional areas calculated in step (iv) above.*

69.119 SPACES DEDUCTED FROM GROSS TONNAGE

(a) PURPOSE

This section lists the requirements for spaces (other than propelling machinery spaces under §69.121), which, though included in calculating gross tonnage (i.e., are not exempt under §69.117), are deducted from gross tonnage in deriving net tonnage.

(b) GENERAL

The following general requirement apply for spaces to be deducted from gross tonnage:

- (1) **General Restrictions** A deductible space must be used exclusively for, and be reasonable in size for, its intended purpose.
- (2) **Working Space** When a space is larger than necessary for the safe and efficient operation of deductible equipment, only the space occupied by the equipment plus a two foot maximum working space on each side of the equipment, if available, is deductible.
- (3) **Location** Space specified in this section may be located anywhere within the vessel, unless otherwise specified.

(c) ANCHOR GEAR

A space below the line of the uppermost complete deck, occupied by the anchor gear, capstan, windlass, and chain locker is deductible. A fore peak used exclusively as a chain locker is measured by the method prescribed under §69.117(g)(3).

(d) BOATSWAIN'S STORES

A space containing oils, blocks, hawsers, rigging, deck gear, or other boatswain's stores for daily use is deductible. The maximum deduction allowed for vessels less than 100 gross tons is one ton and, for vessels 100 gross tons or over, is one percent of the gross tonnage, not to exceed 100 tons.

(e) CHART ROOM

A space for keeping charts and nautical instruments and for plotting the vessel's course is deductible. For a combined wheelhouse and chart room, that part not exempted as wheelhouse under §69.117(b)(9) is deductible. For small vessels in which the only space for a chart room is in a cabin or saloon, one half the space not to exceed 1.5 tons is deductible as chart room.

(f) DONKEY ENGINE AND BOILER

Donkey engine and boiler space is deductible when connected with the main (non-cargo) pumps of the vessel, except as follows:

- (1) ***Space within Engine Room or Casing*** If the space is within the engine room or within the casing above the engine room and if the donkey engine is an auxiliary to the main propelling machinery, the space is an engine room deduction under §69.121(b).
- (2) ***Space above Uppermost Complete Deck*** If the space is above the line of the uppermost complete deck and if the donkey engine is not an auxiliary to the main propelling machinery, the space is exempt under §69.117(b)

(g) SPACES FOR THE EXCLUSIVE USE OF OFFICERS OR CREW

This section provides minimum requirements for deductible spaces that are for the exclusive use of officers or crew.

- (1) ***Miscellaneous Officer/Crew Spaces*** The following spaces, regardless of their location (unless otherwise noted), are deductible if not used by passengers:
 - (i) Sleeping rooms
 - (ii) Bathrooms with a bath tub or shower but without a water closet
 - (iii) Water closets below the line of the uppermost complete deck serving more than one person, with or without a bath tub or shower. Water closets, regardless of location, that serve only one person or that are accessible only through a stateroom or bedroom serving one person are considered as part of the space they serve and are deductible only if that space is deductible.
 - (iv) Clothes drying rooms
 - (v) Drinking water filtration or distilling plant below the line of the uppermost complete deck.
 - (vi) Hospitals
 - (vii) Mess rooms
 - (viii) Office of the Chief Engineer
 - (ix) Oil skin lockers
 - (x) Pantries
 - (xi) Recreation rooms
 - (xii) Smoking rooms
 - (xiii) Galleys below the line of the uppermost complete deck.
- (2) ***Shops*** Shops for engineers, carpenters, plumbers, or butchers and offices for clerks, pursers, or postmasters are not deductible, wherever located.

(h) MASTER'S CABIN

The master's sleeping room, dressing room, bathroom, observation room, reception room, sitting room, water closet, and office are deductible.

(i) RADIO ROOM

Spaces in which radio apparatus is installed and messages are sent and received and which may provide off-duty operator accommodations are deductible.

(j) STEERING GEAR

Spaces for steering gear below the line of the uppermost complete deck are deductible.

(k) GENERATORS

Spaces for generators below the line of the uppermost complete deck are deductible regardless of what space the generators serve. These spaces may include other equipment necessary for the generator's operation.

(l) PUMP ROOM

Spaces below the line of the uppermost complete deck containing pumps that are not capable of handling cargo and that are not fuel oil transfer pumps considered part of the propelling machinery under §69.121(b)(2)(v) are deductible.

(m) SAIL STOWAGE

A space for stowing sails on a vessel propelled only by sails is deductible up to two and one-half percent of the vessel's gross tonnage.

(n) WASTE MATERIAL SPACE

(1) *Storage Spaces* A tank or collection space, regardless of location, used for the carriage or collection of sewage, garbage, galley waste, trash, slop-oil mixture, tank cleaning residue, bilge residue, or other waste material generated aboard the vessel is deductible.

(2) *Processing Spaces* Space below the line of the uppermost complete deck used exclusively to separate, clarify, purify, or otherwise process waste material generated aboard the vessel is deductible.

(o) PASSAGEWAYS

A passageway or companionway is deductible -

(1) If it serves deductible spaces only; or

(2) If it serves deductible spaces and is also the sole means of access to one of the following non-deductible spaces:

(i) Lockers of less than two tons each, containing medicine, linen, mops, or other items for the free use of the crew.

(ii) A ship's office.

(iii) Spare rooms (not exceeding two) used by a pilot, customs officer, reserve engineer, or employee or agent of the vessel's owner or operator.

(p) MARKINGS FOR DEDUCTIBLE SPACES

This section provides minimum requirements for marking of deductible spaces.

- (1) **General** Each space deducted under this section must be marked with the words “Certified _____” (inserting the space designation, such as “Seaman”, “Generator”, “Office of Chief Engineer”, “Hospital”, or “Anchor Gear”). If a deductible space berths more than one crew member, the marking must indicate the number of crew members berthed, such as “Certified _____ Seaman” (inserting the number of crew).
- (2) **Abbreviations** The abbreviations “Cert.” for “certified” and “W.C.” for “water closet” may be used.
- (3) **Lettering** The markings must be in Roman letters and Arabic numerals at least 1/2 inch in height, must be painted in a light color on a dark background, must be embossed, center-punched, carved, or permanently cut in a bulkhead or metal plate, and must be placed in a legible location over a doorway on the inside of the space. A metal plate, if used, must be permanently fastened in place by welding, riveting, lock screws, or a Coast Guard-approved bonding agent.

(q) **METHOD FOR MEASURING DEDUCTIBLE SPACES**

This section provides general requirements for measuring deductible spaces.

- (1) **Rectangular Spaces** A rectangular space must be measured by taking the product of its length, breadth, and height.
- (2) **Spaces with Curved Sides Above Tonnage Deck** A space with curved sides on or above the tonnage deck is measured according to §69.109.
- (3) **Spaces Less Than 15 Feet Long** Space less than 15 feet in length may be measured by any practical method.
- (4) **Spaces with Curved Sides Below Tonnage Deck** Spaces below the tonnage deck exceeding 15 feet in length and bounded by a curved surface conforming to the side of the vessel must be measured by the formula used for measuring the superstructure under §69.113.
- (5) **Spaces on Platforms** The height of a space located on a platform in the hull must be measured from the top of the bottom hull frames, if the platform is used only to form a flat surface at the bottom of the space, if the platform is not more than one foot above the top of the bottom frames, and if the space below the platform is not usable.
- (6) **Treatment of Ceiling** The height of a space is measured through any ceiling, paneling, false overhead, or other covering, to the space’s structural boundary, unless the space enclosed by the covering is available for a non-deductible use.

69.121 ENGINE ROOM DEDUCTION

(a) **GENERAL**

The engine room deduction is either a percentage of the vessel’s total propelling machinery spaces or a percentage of the vessel’s gross tonnage.

(b) **PROPELLING MACHINERY SPACES**

- (1) **General** Propelling machinery spaces are the spaces occupied by the main propelling machinery and auxiliary machinery and spaces reasonably necessary for the operation and maintenance of the machinery. Propelling machinery spaces do not include spaces for fuel tanks, spaces exempt

from gross tonnage under §69.117, and spaces not used or not available for use in connection with propelling machinery.

(2) *Specific Spaces* Propelling machinery spaces are -

- (i)** Space below the crown. The crown is the top of the main space of the engine room to which the heights of the main space are taken. The crown is either the underside of a deck or, if the side bulkheads are sloping, the uppermost point at which the slope terminates. (See 69.123, figures 13 and 14).
- (ii)** Framed-in space located between the crown and the uppermost complete deck and used for propelling machinery or for the admission of light or air to propelling machinery spaces. (See §69.123, figures 13 and 14).
- (iii)** Shaft tunnel space and thrust block recess space.
- (iv)** Space below the uppermost complete deck used for escape shafts or trunked ladderways leading from the aft end of the shaft tunnel to the deck above.
- (v)** Space containing a fuel oil transfer pump located in a separate space and not used for bunkering the vessel. When the pump serves both ballast and fuel oil, only one-half of the pump's space is considered a propelling machinery space.
- (vi)** Spaces containing fuel oil settling tanks used solely for the main boilers. The space must not exceed one percent of the vessel's gross tonnage.
- (vii)** Spaces for engineers' stores and workshops located below the uppermost complete deck and either open to a propelling machinery space or separated from a propelling machinery space only by a screen bulkhead. The space must not exceed three-quarters of one percent of the vessel's gross tonnage.
- (viii)** Framed-in space located above the line of the uppermost complete deck and used for propelling machinery or for the admission of light or air to a propelling machinery space, when requested under paragraph (d) of this section.
- (ix)** If the propelling machinery is boxed-in below the tonnage deck, the boxed-in spaces plus the spaces outside of the boxing for the shaft, auxiliary engines, and related propelling machinery. If a portion of the boxed-in space extends above a platform or partial deck that is below the uppermost complete deck, that portion is also considered part of the propelling machinery space.

(c) METHODS FOR MEASURING PROPELLING MACHINERY SPACES

This section provides requirements for measuring propelling machinery spaces.

- (1)** If the propelling machinery space is bulkheaded off or is not larger than necessary for the safe operation and maintenance of the propelling machinery, the entire space, or, if bulkheaded off, the portion bulkheaded off, is measured for the engine room deduction.
- (2)** If the propelling machinery space is not bulkheaded off or is larger than necessary for the safe operation and maintenance of the propelling machinery, only the space occupied by the propelling machinery itself plus a working space of two feet, if available, on each side of the

- propelling machinery is measured for the engine room deduction. If the working space overlaps another working space not related to the propelling machinery, only one-half of the overlapping working spaces is included in the propelling machinery space. The height of the working space is measured as provided in paragraph (c) of this section.
- (3) If the propelling machinery is located in more than one space, each space must be measured separately.
 - (4) If the propelling machinery is located in a space with a step in the bottom or side lines, each stepped portion of the space must be measured separately.
 - (5) The length of a space under paragraph (c)(1) of this section is measured from the bulkhead just forward of the propelling machinery to the bulkhead just aft of the propelling machinery. The length of a space under paragraph (c)(2) of this section is measured from the forward edge of the working space to the aft edge of the working space.
 - (6) If the boundaries of the propelling machinery space form a rectangle, the product of the length, breadth, and height, divided by 100, is the tonnage of the space.
 - (7) If the boundaries of the propelling machinery space are continuous fair lines, heights are measured at the fore and aft ends and at the center of the space from the bottom frames, floors, or tank top of a double bottom (*water ballast*) up to the line of the crown. A breadth is measured at half-height of each height. The product of the length, mean breadth, and mean height, divided by 100, is the tonnage of the space.
 - (8) If the propelling machinery space is in the aft end of the hull, extends from side to side of the hull, and has a continuous bottom line, the length of the space is divided into the even number of equal parts most nearly equal to the number of parts that the tonnage length under §69.109(g) was divided. The tonnage is then calculated by the same method used for calculating the under-deck tonnage in §69.109(l).
 - (9) The tonnage of a framed-in space located between the crown and the uppermost complete deck and used for propelling machinery or for the admission of light or air to the propelling machinery space, is the product of its length, breadth, and height, divided by 100.
 - (10) The tonnage of a shaft tunnel, or a thrust block recess, having a flat top is the product of its length, breadth, and height, divided by 100. If the shaft tunnel or thrust block recess top is not flat, the space above must be calculated by using the appropriate geometrical formula. If the space aft of the shaft tunnel extends from side to side of the vessel, the tonnage of the space is found by the formula for measuring peak tanks in §69.109(l).
 - (11) The length and breadth of the space for the shaft tunnel, or a thrust block recess, when not cased is that which is necessary for maintenance of the shaft. The height allowed for thrust block recess space must not exceed seven feet. The mean height allowed for the shaft tunnel space must not exceed six feet. In a multi-screw vessel where the shaft tunnel or thrust block recess space is open from side to side, measure only the space used for purposes of propelling the vessel.
 - (12) When the propelling machinery is on a bed at the vessel's bottom, the height of the propelling machinery space is measured from the top of the bottom frames or floors.

(d) ENGINE ROOM SPACES ABOVE LINE OF THE UPPERMOST COMPLETE DECK

Spaces meeting the specific requirements below may also be deducted as propelling machinery space. Requests to treat certain framed-in engine room spaces as part of a propelling machinery space must be submitted in accordance with paragraph (1) below.

- (1) Under §69.117(b)(4), framed-in spaces located above the line of the uppermost complete deck and used for propelling machinery or for admitting light or air to a propelling machinery space are exempt from inclusion in tonnage. However, upon written request to a measurement organization listed in §69.15, the vessel owner may elect to have these spaces included in calculating gross tonnage, then deducted from gross tonnage as propelling machinery spaces under paragraph (b)(2)(viii) of this section.
- (2) The framed-in space must be safe, seaworthy, and used only for propelling machinery or for the admission of light or air to the propelling machinery space. The length of the space must not exceed the length of the propelling machinery space and the breadth must not exceed one-half of the extreme inside midship breadth of the vessel. Portions of the framed-in space that are plated over are not included in the propelling machinery space.
- (3) To exercise the option in paragraph (d)(1) of this section, all of the framed in space need not be treated as propelling machinery space, but only that portion required to entitle the vessel to have 32 percent of its gross tonnage deducted as an engine room deduction under paragraph (e) of this section.

(e) CALCULATING THE ENGINE ROOM DEDUCTION

- (1) **General** The engine room deduction is based on a percentage of the vessel's gross tonnage or a percentage of the total propelling machinery space.
- (2) **Vessels Propelled by Screw** For vessels propelled in whole or in part by screw -
 - (i) If the total propelling machinery space is 13 percent or less of the vessel's gross tonnage, deduct 32/13 times the total propelling machinery space;
 - (ii) If the total propelling machinery space is more than 13 but less than 20 percent of the vessel's gross tonnage, deduct 32 percent of the vessel's gross tonnage; or
 - (iii) If the total propelling machinery space is 20 percent or more of the vessel's gross tonnage, deduct either 32 percent of the vessel's gross tonnage or 1.75 times the total propelling machinery space, whichever the vessel's owner elects.
- (3) **Vessels Propelled by Paddle Wheel** For vessels propelled in whole or in part by paddle-wheel -
 - (i) If the total propelling machinery space is 20 percent or less of the vessel's gross tonnage, deduct 37/20 times the total propelling machinery space;
 - (ii) If the total propelling machinery space is more than 20 but less than 30 percent of the vessel's gross tonnage, deduct 37 percent of the vessel's gross tonnage; or
 - (iii) If the total propelling machinery space is 30 percent or more of the vessel's gross tonnage, deduct either 37 percent of the vessel's gross tonnage or 1.5 times the total propelling machinery space, whichever the vessel's owner elects.

DUAL MEASUREMENT SYSTEM



INTERPRETATIONS

TABLE OF CONTENTS

69.151 PURPOSE	3
69.153 APPLICATION OF OTHER LAWS	3
(a) <i>USE OF HIGHER TONNAGE</i>	3
(b) <i>LOAD LINE REQUIREMENTS</i>	3
69.155 MEASUREMENT REQUIREMENTS	3
69.157 DEFINITIONS	3
69.159 APPLICATION FOR MEASUREMENT SERVICES	4
69.161 GROSS AND NET TONNAGES	4
69.163 UNDER-DECK TONNAGE	4
69.165 BETWEEN-DECK TONNAGE	4
69.167 SUPERSTRUCTURE TONNAGE	4
69.169 SPACES EXEMPT FROM INCLUSION IN GROSS TONNAGE	4
(a) <i>MISCELLANEOUS EXEMPTIBLE SUPERSTRUCTURE SPACES</i>	4
(b) <i>PASSENGER SPACES</i>	5
(c) <i>WATER BALLAST SPACES</i>	5
(d) <i>DRY CARGO AND STORES SPACES</i>	5
(e) <i>ADDITIONAL EXEMPTIONS FOR LOW TONNAGE</i>	5
69.171 WHEN THE TONNAGE MARK IS CONSIDERED SUBMERGED	5
69.173 TONNAGE ASSIGNMENTS FOR VESSELS WITH ONLY ONE DECK	5
69.175 TONNAGE ASSIGNMENTS FOR VESSELS WITH A SECOND DECK	5
(a) <i>GENERAL</i>	5
(b) <i>HIGH / LOW TONNAGES ASSIGNED</i>	5
(c) <i>ONLY LOW TONNAGES ASSIGNED</i>	6
69.177 MARKINGS	6
(a) <i>TONNAGE MARK</i>	6
(b) <i>LINE FOR FRESH AND TROPICAL WATERS</i>	8
(c) <i>FREEBOARD DECK MARK</i>	8
(d) <i>THE LINE OF THE SECOND DECK</i>	8
(e) <i>COLOR OF MARKINGS</i>	8
69.179 CERTIFICATION OF MARKINGS	8
(a) <i>MEASUREMENT ORGANIZATION CERTIFICATION</i>	8
(b) <i>COAST GUARD VERIFICATION</i>	9
69.181 LOCATING THE LINE OF THE SECOND DECK	9
(a) <i>SECOND DECK NOT STEPPED</i>	9
(b) <i>SECOND DECK IS STEPPED</i>	9
69.183 FIGURES	10
(a) <i>TONNAGE MARK AND TRIANGLE</i>	10
(b) <i>TONNAGE MARK LOCATION (High and Low Tonnages)</i>	10
(c) <i>TONNAGE MARK LOCATION (Low Tonnages Only)</i>	11

DUAL MEASUREMENT SYSTEM (46 CFR 69 SUBPART D)

69.151 PURPOSE

This subpart prescribes measurement requirements for the assignment of either one gross and one net tonnage or two gross and two net tonnages to vessels under the Dual Measurement System.

69.153 APPLICATION OF OTHER LAWS

(a) *USE OF HIGHER TONNAGE*

If a vessel is assigned two gross tonnages under §69.175(b), the higher gross tonnage is the tonnage used when applying inspection, manning, and load line laws and regulations to the vessel.

(b) *LOAD LINE REQUIREMENTS*

Tonnage marks are not to be construed as additional load line marks. Whether or not a tonnage mark is submerged under §69.171 has no effect on the applicability of load line laws and regulations.

69.155 MEASUREMENT REQUIREMENTS

Except as otherwise required by this subpart, the measurement requirements under the Standard Measurement System in subpart C of this part apply to the measurement of vessels under the Dual Measurement System.

69.157 DEFINITIONS

Terms used in this subpart that are defined in §69.103 have the same meaning as in §69.103, except the terms listed below. As used in this subpart,—

GROSS TONNAGE is defined in §69.161(a).

LINE FOR FRESH AND TROPICAL WATERS means the line described in §69.177(b)(2).

LINE OF THE SECOND DECK means the line described in §69.181.

LINE OF THE UPPERMOST COMPLETE DECK means a longitudinal line at the underside of the uppermost complete deck or, if that deck is stepped, the longitudinal line of the underside of the lowest portion of that deck parallel with the upper portions of that deck.

NET TONNAGE is defined in §69.161(b).

SECOND DECK means the next deck below the uppermost complete deck that meets the following:

- (a) Is continuous athwartships and in a fore-and-aft direction at least between peak bulkheads, even though the deck may have interruptions or openings due to propelling machinery spaces, to hatch and ventilation trunks not extending longitudinally completely between main transverse bulkheads, to ladder and stairway openings, to chain lockers, or to cofferdams.
- (b) Is fitted as an integral and permanent part of the vessel.
- (c) Has proper covers to all main hatchways.
- (d) Does not have steps the total of which exceed 48 inches in height.

TONNAGE DECK means, for a vessel with only one deck, the uppermost complete deck and, for a vessel with a second deck, the second deck.

TONNAGE MARK means the line described in §69.177(a)(2).

69.159 APPLICATION FOR MEASUREMENT SERVICES

Applications for measurement services under this subpart must include the application information and plans required for the Standard Measurement System under §69.105. The application must indicate whether a line for fresh and tropical waters is requested under §69.177(b) and, for vessels with more than one deck, indicate whether one or two sets of tonnages are desired under §69.175.

69.161 GROSS AND NET TONNAGES

- (a) Gross tonnage means the tonnage of a vessel, less certain spaces exempt under §69.169, and is the sum of the following:
- (1) Under-deck tonnage (§69.163)
 - (2) Between-deck tonnage (§69.165)
 - (3) Superstructure tonnage (§69.167)
 - (4) Excess hatchway tonnage (§69.115)
 - (5) Tonnage of framed-in propelling machinery spaces included in calculating gross tonnage (§69.121(d)(1)).
- (b) Net tonnage means gross tonnage less deductions under §69.119 and §69.121.

69.163 UNDER-DECK TONNAGE

The under-deck tonnage provisions in §69.109 apply; except that, under the Dual Measurement System, spaces between the line of the tonnage deck and the tonnage deck itself due to a stepped tonnage deck are included in under-deck tonnage.

69.165 BETWEEN-DECK TONNAGE

The between-deck tonnage provisions in §69.111 apply, except that, under the Dual Measurement System, between-deck space extends from the tonnage deck to the uppermost complete deck, rather than from the line of the tonnage deck to the line of the uppermost complete deck.

69.167 SUPERSTRUCTURE TONNAGE

The superstructure tonnage provisions in §69.113 apply; except that, under the Dual Measurement System, spaces between the line of the uppermost complete deck and the uppermost complete deck itself due to a stepped uppermost complete deck are not included in the superstructure tonnage.

69.169 SPACES EXEMPT FROM INCLUSION IN GROSS TONNAGE

The tonnage of the following spaces is exempt from inclusion in gross tonnage:

- (a) ***MISCELLANEOUS EXEMPTIBLE SUPERSTRUCTURE SPACES***
Spaces listed in §69.117(b) when located within the superstructure.

69.171 When the Tonnage Mark is Considered Submerged**(b) PASSENGER SPACES**

Spaces listed in §69.117(c)(1) through (c)(3) when located above, but not on, the uppermost complete deck.

(c) WATER BALLAST SPACES

Spaces listed in §69.117(f), regardless of location.

(d) DRY CARGO AND STORES SPACES

Spaces available for carrying dry cargo and stores when located on or above the uppermost complete deck.

(e) ADDITIONAL EXEMPTIONS FOR LOW TONNAGE

When a vessel is assigned a tonnage mark and the tonnage mark is not submerged,—

(1) Miscellaneous Exemptible Spaces Spaces listed in §69.117(b) when located between the uppermost complete deck and the second deck;

(2) Passenger Spaces on the Uppermost Complete Deck Spaces listed in §69.117(c)(1) through (c)(3) when located on the uppermost complete deck; and

(3) Dry Cargo and Stores Spaces Spaces available for carrying dry cargo and stores when located between the uppermost complete deck and the second deck.

69.171 WHEN THE TONNAGE MARK IS CONSIDERED SUBMERGED

For the purpose of this subpart, a tonnage mark is considered submerged when—

(a) In salt or brackish water, the upper edge of the tonnage mark is submerged; and

(b) In fresh or tropical water, the upper edge of the line for fresh and tropical waters is submerged.

69.173 TONNAGE ASSIGNMENTS FOR VESSELS WITH ONLY ONE DECK

A vessel without a second deck is assigned only one gross and one net tonnage. In calculating the gross tonnage, only the exemptions in §69.169 (a) through (d) are allowed. Markings under §69.177 are not permitted on these vessels.

69.175 TONNAGE ASSIGNMENTS FOR VESSELS WITH A SECOND DECK**(a) GENERAL**

At the option of the vessel owner, a vessel having a second deck is assigned either: 1) two gross and two net tonnages; or 2) one gross and one net tonnage *corresponding to the lower gross and net tonnage*.

(b) HIGH / LOW TONNAGES ASSIGNED

If two gross and two net tonnages are assigned, the higher tonnages (i.e. those based only on exemptions under §69.169 (a) through (d)) are applicable when the upper edge of the tonnage mark is submerged and the lower tonnages (i.e. those based only on all exemptions under §69.169) are applicable when the upper edge of the tonnage mark is not submerged.

(c) ONLY LOW TONNAGES ASSIGNED

If only the low gross and low net tonnages, as calculated under paragraph (b) of this section, are assigned, these tonnages are applicable at all times. On these vessels, *a load line must be assigned at a level below the line of the second deck, and the tonnage mark must be located in accordance with §69.177(a)(6) at the level of the uppermost part of the load line grid.*

69.177 MARKINGS

The following table provides an overview of the marking requirements of this section:

GENERAL TONNAGE MARKING REQUIREMENTS		
	<u>Load Line Assigned</u>	<u>Load Line Not Assigned</u>
<u>Two Deck Vessel</u>		
HIGH AND LOW TONNAGES	Must have tonnage mark with triangle	Must have tonnage mark with triangle, and freeboard deck mark
LOW TONNAGES ONLY	Must have tonnage mark with triangle	Ineligible for measurement under Dual Measurement System
<u>One Deck Vessel</u>	No tonnage markings on hull	No tonnage markings on hull

(a) TONNAGE MARK

- (1) **General** All vessels with a second deck that are measured under the Dual Measurement System must have, on each side of the vessel, a tonnage mark, and an inverted triangle identifying the tonnage mark, as described and located under this section. (See the figure in §69.183(a).) Vessels with only one deck are not assigned markings under this section.
- (2) **Tonnage Mark Characteristics** The tonnage mark is a horizontal line 15 inches long and one inch wide. The tonnage mark must be designated by a welded bead or other permanent mark 15 inches long placed along the top edge of the tonnage mark.
- (3) **Inverted Triangle Characteristics** Above the tonnage mark is placed an inverted equilateral triangle, each side of which is 12 inches long and one inch wide, with its apex touching the upper edge of the center of the tonnage mark.
- (4) **Longitudinal Placement** If the vessel has a load line mark, the longitudinal location of the center of the tonnage mark must be between 21 inches and six feet six inches aft of the vertical centerline of the load line ring. (See the figures in §69.183 (b) and (c).) If the vessel does not have a load line mark, the center of the tonnage mark must be located amidships.
- (5) **Vertical Placement (High / Low Tonnages Assigned)** Except as under paragraph (a)(6) of this section, the upper edge of the tonnage mark must be located below the line of the second deck at the distance indicated in Table 69.177(a)(5). (See the figure in §69.183(b).)

TABLE 69.177(a)(5)—MINIMUM DISTANCE IN INCHES BETWEEN THE TONNAGE MARK AND THE LINE OF THE SECOND DECK

L (in feet)	L divided by D								
	12	13	14	15	16	17	18	19	20
220 and under	2.0	2.0	2.0	2.0	2.0	2.0	2.0	2.0	2.0
230	3.2	2.0	2.0	2.0	2.0	2.0	2.0	2.0	2.0
240	4.7	2.0	2.0	2.0	2.0	2.0	2.0	2.0	2.0
250	6.3	3.3	2.0	2.0	2.0	2.0	2.0	2.0	2.0
260	8.0	4.8	2.1	2.0	2.0	2.0	2.0	2.0	2.0
270	9.9	6.4	3.5	2.0	2.0	2.0	2.0	2.0	2.0
280	11.8	8.1	4.9	2.1	2.0	2.0	2.0	2.0	2.0
290	13.9	9.9	6.5	3.5	2.0	2.0	2.0	2.0	2.0
300	16.0	11.7	8.1	4.9	2.1	2.0	2.0	2.0	2.0
310	18.3	13.7	9.8	6.4	3.5	2.0	2.0	2.0	2.0
320	20.7	15.8	11.7	8.1	4.9	2.1	2.0	2.0	2.0
330	23.2	18.0	13.6	9.8	6.4	3.5	2.0	2.0	2.0
340	25.9	20.4	15.7	11.6	8.1	4.9	2.1	2.0	2.0
350	28.7	22.9	17.9	13.6	9.8	6.5	3.6	2.0	2.0
360	31.7	25.5	20.2	15.7	11.7	8.2	5.0	2.2	2.0
370	34.7	28.3	22.7	17.9	13.6	9.9	6.6	3.7	2.0
380	38.0	31.1	25.3	20.2	15.7	11.8	8.3	5.2	2.4
390	41.3	34.1	27.9	22.6	17.9	13.8	10.1	6.8	3.8
400	44.8	37.2	30.7	25.0	20.1	15.8	11.9	8.4	5.3
410	48.2	40.3	33.5	27.7	22.6	18.1	14.0	10.4	7.2
420	51.5	43.4	36.4	30.4	25.2	20.6	16.4	12.7	9.7
430	54.8	46.5	39.4	33.3	27.9	23.2	19.0	15.2	11.8
440	58.4	49.9	42.6	36.4	30.9	26.0	21.7	17.8	14.4
450	62.1	53.4	46.0	39.6	33.9	29.0	24.6	20.6	17.1
460	65.9	57.0	49.5	42.9	37.1	32.1	27.6	23.5	19.9
470	69.8	60.7	53.0	46.3	40.4	35.2	30.6	26.5	22.8
480	73.7	64.4	56.5	49.7	43.7	38.4	33.7	29.5	25.7
490	77.5	68.1	60.0	53.0	46.9	41.5	36.7	32.4	28.5
500	81.2	71.6	63.4	56.2	50.0	44.5	39.6	35.2	31.2
510	84.9	75.1	66.7	59.4	53.0	47.4	42.4	37.9	33.9
520	88.4	78.4	69.9	62.4	55.9	50.2	45.1	40.5	36.4
530	91.8	81.6	72.9	65.3	58.7	52.9	47.7	43.0	38.8
540	95.2	84.8	75.9	68.1	61.4	55.5	50.2	45.4	41.2
550	98.4	87.8	78.8	70.9	64.0	58.0	52.6	47.8	43.4
560	101.6	90.8	81.6	73.6	66.6	60.5	55.0	50.1	45.6
570	104.8	93.8	84.4	76.3	69.2	62.9	57.3	52.3	47.8
580	107.9	96.8	87.2	78.9	71.7	65.3	59.6	54.5	49.9
590	111.0	99.7	90.0	81.5	74.2	67.7	61.9	56.7	52.0
600	114.0	102.5	92.6	84.0	76.5	69.9	64.0	58.8	54.0
610	117.0	105.3	95.2	86.5	78.9	72.1	66.2	60.8	56.0
620	120.0	108.0	97.8	88.9	81.2	74.4	68.3	62.8	58.0
630	122.9	110.7	100.4	91.3	83.5	76.6	70.4	64.8	59.9
640	125.7	113.4	102.9	93.7	85.8	78.7	72.4	66.8	61.7
650	128.6	116.1	105.4	96.1	88.0	80.8	74.4	68.7	63.6
660	131.4	118.7	107.8	98.3	90.1	82.8	76.3	70.6	65.3
670	134.2	121.2	110.2	100.6	92.2	84.8	78.3	72.4	67.1
680	136.9	123.8	112.8	102.9	94.3	86.8	80.2	74.2	68.9
690	139.6	126.3	115.0	105.1	96.4	88.8	82.1	76.0	70.6
700	142.3	128.8	117.3	107.3	98.5	90.8	83.9	77.8	72.3
710	144.9	131.3	119.6	109.4	100.5	92.7	85.7	79.5	73.9
720	147.5	133.7	121.8	111.5	102.5	94.6	87.5	81.2	75.5
730	150.1	136.1	124.0	113.6	104.5	96.5	89.3	82.9	77.1
740	152.7	138.5	126.2	115.7	106.5	98.3	91.5	84.5	78.7
750	155.3	140.8	128.5	117.8	108.4	100.1	92.8	86.1	80.3
760	157.8	143.1	130.6	119.7	110.3	101.9	94.4	87.8	81.7
770	160.2	145.4	132.7	121.7	112.1	103.6	96.0	89.3	83.2
780	162.6	147.6	134.8	123.7	113.9	105.3	97.6	90.8	84.7
790	165.1	149.9	136.9	125.6	115.7	107.0	99.2	92.3	86.1
800	167.5	152.1	138.9	127.4	117.4	108.6	100.8	93.8	87.4

L=the length in feet of the line of the second deck at the centerline of the vessel from the inner surface of the frames at the vessel's stem to the inner surface of the frames at the vessel's stern.

D=The vertical distance in feet from the top of the flat keel of the vessel to the line of the second deck.

EXAMPLE (1) For a vessel in which L=490 feet and L/D=15 feet, read down from the L/D column "15" and to the right on the column "490" to where the two columns intersect at 39.6. The tonnage mark must be located 39.6 inches below the line of the second deck.

EXAMPLE (2) If L or L/D is an intermediate number, the distance "a" between the tonnage mark and the line of the second deck must be obtained by linear interpolation. For a vessel in which L=424.80 feet and L/D=15.17:

L	Table L/ D=15	Actual L/ D=15.17	Table L/ D=16
Table 420	30.4		25.2
Actual 424.80	r	a	s
Table 430	33.3		27.9

Interpolation:

$$r=30.4+0.48(33.3-30.4)=31.79$$

$$s=25.2+0.48(27.9-25.2)=26.50$$

$$a=r-0.17(r-s)=31.79-0.17(31.79-26.50)=30.89 \text{ inches}$$

(6) **Vertical Placement (Low Tonnage Assigned With Load Line)** For the following vessels, which meet the criteria of both subsections (i) and (ii) below and with a load line mark, the upper edge of the tonnage mark must be located at the level of the uppermost part of the load line grid.

(i) Vessels assigned only one gross and one net tonnage under §69.175(c);

(ii) Vessels for which a load line assigning authority certifies that the vessel's load line mark was located as though the second deck were the freeboard deck. *In other words, even if the second deck is not the freeboard deck for load line purposes, the load line must be assigned as if the second deck were the freeboard deck in order for the vessel to be assigned single low tonnages under the Dual Measurement System.*

(b) LINE FOR FRESH AND TROPICAL WATERS

(1) **General** Except as under paragraph (b)(4) of this section, a horizontal line for fresh and tropical waters may be assigned at the vessel owner's request.

(2) **Characteristics of Fresh and Tropical Waters Line** The line must be nine inches long and one inch wide and located above and to the left of the tonnage mark at a distance equal to one forty-eighth of the distance from the top of the flat keel to the tonnage mark. The tonnage mark and the line for fresh and tropical waters must be connected by a vertical line one inch wide. (See the figure in § 69.183(a).)

(3) **Permanent Marking Requirements** The line for fresh and tropical waters must be designated by a welded bead or other permanent mark nine inches long placed along the upper edge of the line.

(4) **Restrictions When Only Low Tonnage is Assigned** For vessels with a load line mark, if the load line assigning authority certifies that the load line mark was located as though the second deck were the freeboard deck, a line for fresh and tropical waters must not be placed on the vessel.

(c) FREEBOARD DECK MARK

A vessel assigned two gross and two net tonnages which has more than one deck and no load line mark assigned must have a mark on each side of the vessel with the same dimensions and location as the freeboard deck line mark under §42.13–20 of this chapter, except that the mark must be located directly above the tonnage mark.

(d) THE LINE OF THE SECOND DECK.

The line of the second deck must not be marked on the side of the vessel. *This prohibition shall not be construed to prohibit the assignment of a freeboard deck line mark under load line requirements at the location of the second deck if the second deck is the actual freeboard deck for purposes of load line assignment.*

(e) COLOR OF MARKINGS

All markings under this section must be maintained in either a light color on a dark background or a dark color on a light background.

69.179 CERTIFICATION OF MARKINGS

(a) MEASUREMENT ORGANIZATION CERTIFICATION

Before a certificate of measurement is issued for a vessel requiring a tonnage mark, a certification by a measurement organization under §69.15 that all markings meet the requirements of this subpart is

required. As a minimum, this certification should consist of a signed written statement attesting to the following:

- (1) **Tonnage Mark and Triangle** The tonnage mark and associated inverted triangle are properly installed on both sides of the vessel, with the tonnage mark below the line of the second deck.
- (2) **Freeboard Deck Mark** For vessels without a load line assigned, the freeboard deck mark is properly installed on both sides of the vessel.

(b) **COAST GUARD VERIFICATION**

The Coast Guard, at any time, may verify markings under this subpart.

69.181 LOCATING THE LINE OF THE SECOND DECK

(a) **SECOND DECK NOT STEPPED**

If the second deck is not stepped, the line of the second deck is the longitudinal line of the underside of the second deck at the side of the hull.

(b) **SECOND DECK IS STEPPED**

If the second deck is stepped (as in the examples following this paragraph), the line of the second deck is a longitudinal line extended parallel to each portion of the second deck and located at the height of the underside of the amidships portion of the second deck at the side of the hull—

- (1) Plus, for each stepped portion of the second deck higher than the second deck at amidships, a distance equal to the length of the stepped portion divided by the total length of the second deck times the height that the step is above the height of the amidship portion of the second deck; and
- (2) Minus, for each stepped portion of the second deck lower than the second deck at amidships, a distance equal to the length of the stepped portion divided by the total length of the second deck times the height that the amidship portion of the second deck is above the height of the step.

EXAMPLE: (1)

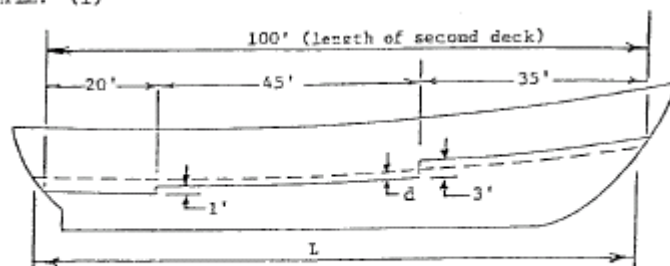

L = Length of the line of the second deck.
 d = Distance from amidship portion of second deck to line of second deck.

$$d = \frac{35 \times 3}{100} - \frac{20 \times 1}{100} = + 0.85 \text{ feet.}$$

EXAMPLE: (2)

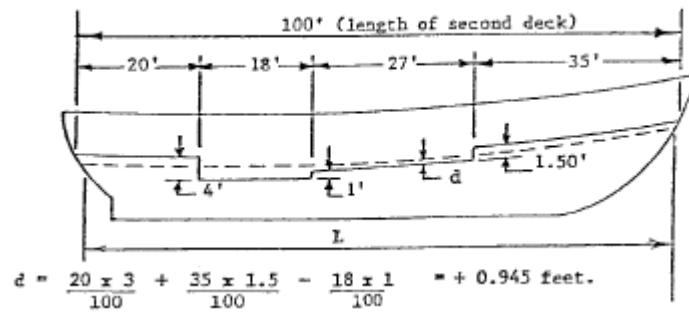

69.183 FIGURES

(a) **TONNAGE MARK AND TRIANGLE**

Tonnage mark with an equilateral triangle and a line for fresh and tropical waters.

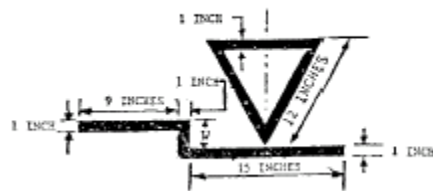

W = 1/4 of the distance from the top of the flat keel to the tonnage mark. (See §69.177(b)(2).)

(b) **TONNAGE MARK LOCATION (High and Low Tonnages)**

Tonnage mark location if the load line mark is not placed as though the second deck were the freeboard deck for load line purposes, but rather is placed on the basis that the uppermost complete deck is the freeboard deck.

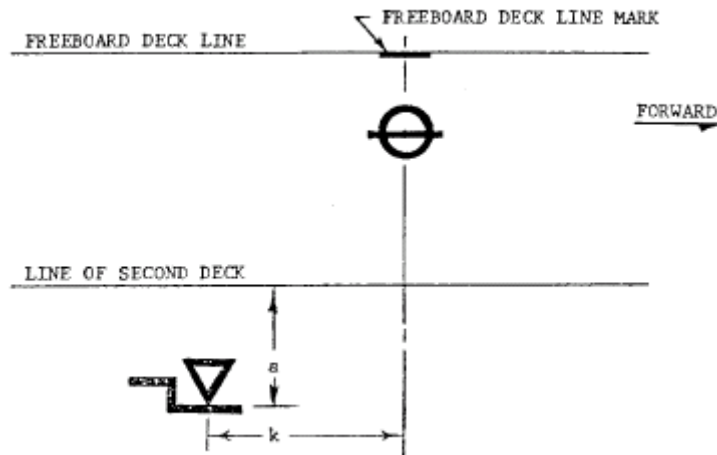

k = a distance between 21 inches and six feet six inches.
a = distance derived from Table 69.177(A)(5).

(c) TONNAGE MARK LOCATION (Low Tonnages Only)

Tonnage mark location if the load line mark is placed as though the second deck were the freeboard deck. In other words, although the second deck does not qualify as the freeboard deck for load line purposes, the load line mark is located by the load line assigning authority as if the second deck qualifies as the freeboard deck. In this figure, the freeboard deck for load line purposes is the uppermost complete deck, and the freeboard deck line mark is correctly shown at the level of the uppermost complete deck.

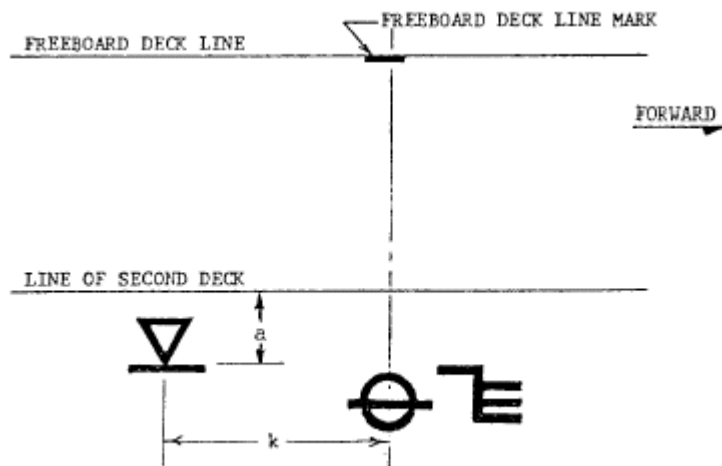

k —a distance between 21 inches and six feet six inches.
 a —the distance between the line of the second deck and the uppermost part of the load line grid.

SIMPLIFIED MEASUREMENT SYSTEM



INTERPRETATIONS

TABLE OF CONTENTS

69.201 PURPOSE	3
69.203 DEFINITIONS	3
69.205 APPLICATION FOR MEASUREMENT SERVICES	5
69.207 MEASUREMENTS	5
69.209 CALCULATION OF TONNAGES	6
(a) GROSS TONNAGE	6
(b) NET TONNAGE	8
(c) <i>TONNAGE OF NOVEL CRAFT</i>	8

SIMPLIFIED MEASUREMENT SYSTEM (46 CFR 69 SUBPART E)

69.201 PURPOSE

This subpart prescribes the procedures for measuring a vessel under the Simplified Measurement System described in 46 U.S.C. chapter 145, subchapter III.

69.203 DEFINITIONS

As used in this subpart, and in Coast Guard Form CG-5397 under § 69.205 –

MULTI-HULL VESSEL means a vessel with more than one distinct hull. To be considered a distinct hull, the hull must connect to another hull only with structure that is not a part of the vessel's buoyant hull envelope.

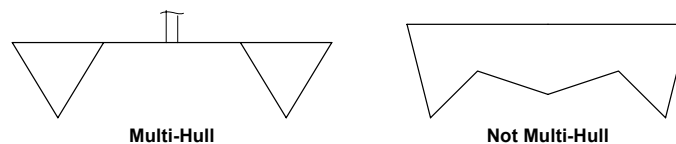

OVERALL BREADTH means the horizontal distance taken at the widest part of the hull, excluding rub rails, from the outboard side of the skin (outside planking or plating) on one side of the hull to the outboard side of the skin on the other side of the hull.

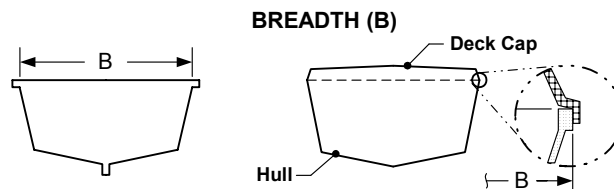

OVERALL DEPTH means the vertical distance taken at or near midships from a line drawn horizontally through the uppermost edges of the skin (outside planking or plating) at the sides of the hull (excluding the cap rail, trunks, cabins, and deckhouses) to the outboard face of the bottom skin of the hull, excluding the keel. *Depth is measured at amidships for all cases except those in which there is a longitudinal discontinuity in the deck that occurs within 5% of the overall length on either side of amidships. In such cases, the greater depth is used.* For a vessel that is designed for sailing and has a keel faired to the hull, the keel is included in the "overall depth" if the distance to the bottom skin of the hull cannot be determined reasonably (See § 69.201(a)(5)).

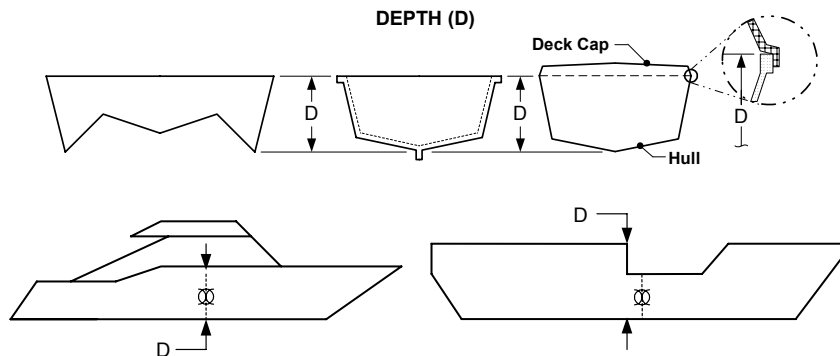

OVERALL LENGTH means the horizontal distance between the outboard side of the foremost part of the stem and the outboard side of the aftermost part of the stern, excluding rudders, outboard motor brackets, and other similar fittings and attachments. *Also excluded from length are non-buoyant attachments such as bulwarks, bowsprits, overhanging decks, swim platforms and stern-wheel supports. Buoyant hull structures both fixed and removable are included in the overall length, and consequently in tonnage.*

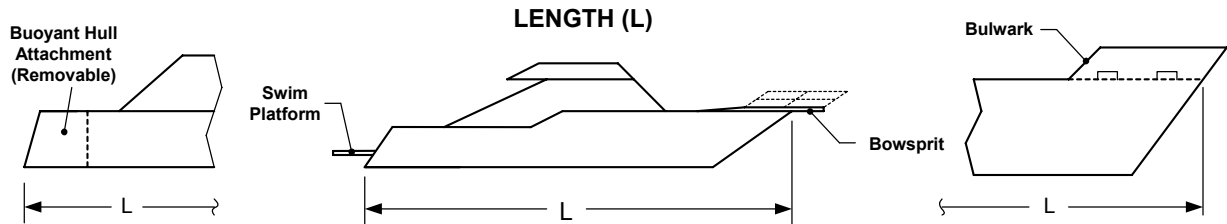

AMIDSHIPS or **MIDSHIPS** means the midpoint of the overall length.

NOTE: The term “overall” as used above for breadth, depth and length differs from the naval architectural term of art for which all extended fittings of the hull are included.

REGISTERED BREADTH means –

- (a) For a single-hull vessel, the vessel’s overall breadth; and
- (b) For a multi-hull vessel, the horizontal distance taken at the widest part of the complete vessel between the outboard side of the skin (outside planking or plating) on the outboardmost side of one of the outboardmost hulls (*e.g., port hull*) to the outboard side of the skin on the outboardmost side of the other outboardmost hull (*e.g., starboard hull*), excluding rubrails.

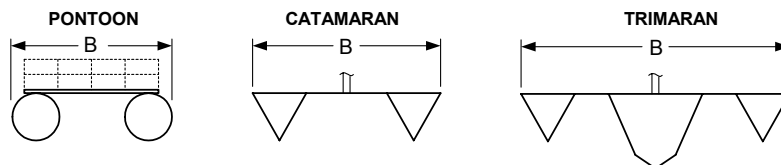

REGISTERED DEPTH means –

- (a) For a single-hull vessel, the vessel’s overall depth; and
- (b) For a multi-hull vessel, the overall depth of the deepest hull.

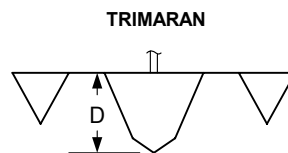

REGISTERED LENGTH means –

- (a) For a single-hull vessel, the vessel's overall length; and
- (b) For a multi-hull vessel, the horizontal distance between the outboard side of the foremost part of the stem of the foremost hull and the outboard side of the aftermost part of the stern of the aftermost hull, excluding fittings and attachments.

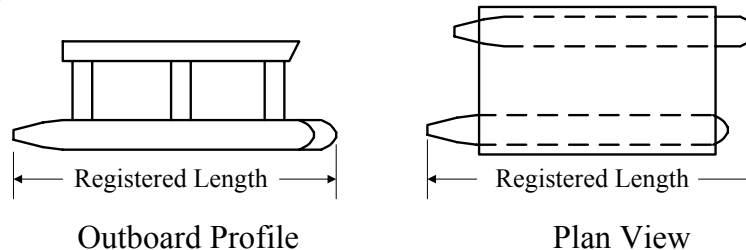

STEM means the foremost boundary of the buoyant hull envelope.

STERN means the aftermost boundary of the buoyant hull envelope.

VESSEL DESIGNED FOR SAILING means a vessel which has the fine lines of a sailing craft and is capable of being propelled by sail, whether or not the vessel is equipped with an auxiliary motor, a decorative sail, or a sail designed only to steady the vessel.

69.205 APPLICATION FOR MEASUREMENT SERVICES

To apply for measurement under the Simplified Measurement System, the owner of the vessel must complete either an Application for Simplified Measurement (form CG-5397), or a Builder's Certification and First Transfer of Title (form CG-1261) which has the information in Part III "Dimensions" completed, and submit it to the National Vessel and Documentation Center (NVDC). *The preceding sentence will be reworded in the next revision of the regulations to state that a vessel owner must submit either an Application (form CG-5397), or a copy of a Builder's Certificate (CG-1261). The former is completed by the vessel owner, and the latter by the vessel builder or manufacturer.*

69.207 MEASUREMENTS

- (a) All lengths and depths must be measured in a vertical plane at centerline and breadths must be measured in a line at right angles to that plane. All dimensions must be expressed in feet and inches to the nearest half inch or in feet and tenths of a foot to the nearest .05 of a foot.

Length is measured in a vertical (longitudinal) plane at the centerline of the hull(s). Breadth is measured in a vertical (transverse) plane at right angles to the centerline at the widest part of the hull. Depth is measured in a vertical (transverse) plane at right angles to the centerline at or near amidships

- (b) For a multi-hull vessel, each hull must be measured separately for overall length, breadth, and depth and the vessel as a whole must be measured for registered length, breadth, and depth.
- (c) The Coast Guard may verify dimensions of vessels measured under this subpart.

69.209 CALCULATION OF TONNAGES

(a) GROSS TONNAGE

- (1) Except as in paragraph (a)(2) through (a)(5) of this section, the gross tonnage of a vessel designed for sailing is one-half of the product of its overall length, overall breadth, and overall depth (LBD) divided by one hundred (i.e., 0.50 LBD/100), and the gross tonnage of a vessel not designed for sailing is 0.67 LBD/100.

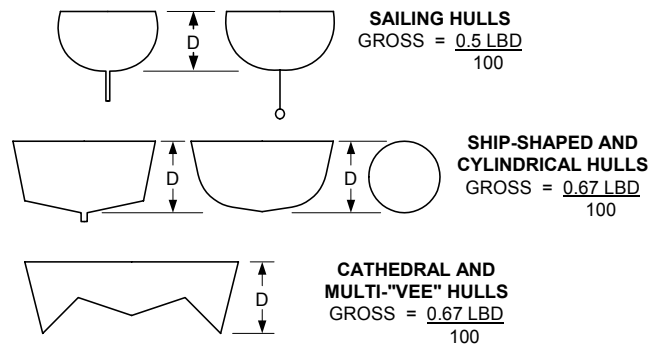

- (2) The gross tonnage of a vessel with a hull that approximates in shape a rectangular geometric solid (barge-shape) is 0.84 LBD/100.

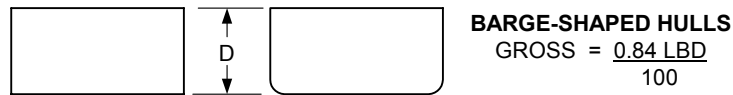

- (3) The gross tonnage of a multi-hull vessel is the sum of all the hulls as calculated under this section.

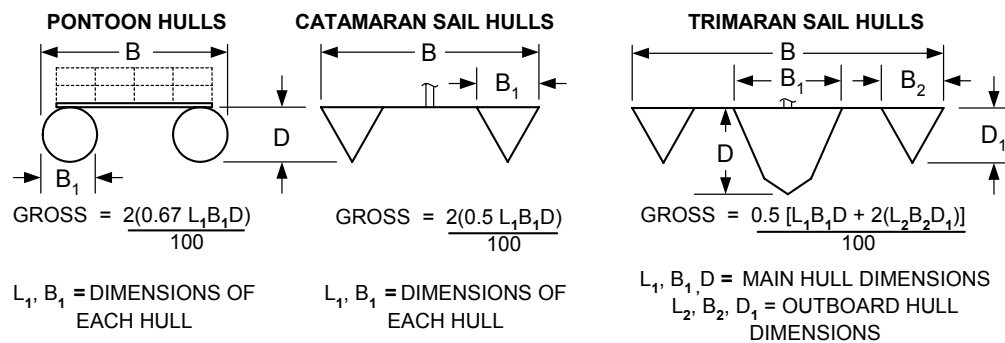

- (4) If the volume of the principal deck structure of a vessel is as large as, or larger than, the volume of the vessel's hull, the volume of the principal deck structure in tons of 100 cubic feet is added to the tonnage of the hull to establish the vessel's gross tonnage. The volume of the principal deck structure of a vessel is determined by the product of its average dimensions.

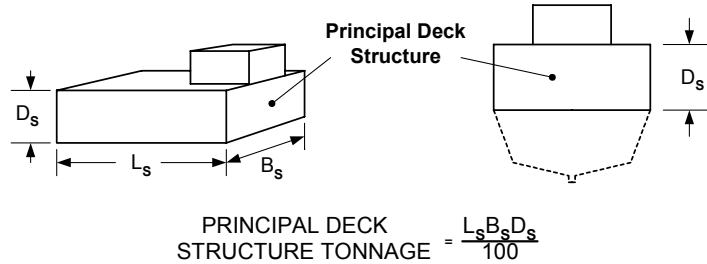

NOTE: A deck structure in this context is as defined in §69.53, and which also qualifies as an enclosed space as defined in §69.59. Deck structures that are comprised entirely of excluded spaces as defined in §69.61 are ignored when calculating tonnage under the simplified measurement system. Conversely, deck structures that are comprised partially of excluded spaces are treated as if the entire structure is closed. Typically, the covered open structure on smaller pontoon boats is ignored from measurement, provided the sides are enclosed only by roll-down canvas or similar temporary awning-like arrangements.

- (5) If the overall depth of a vessel designed for sailing includes the keel, only 75 percent of that depth is used for gross tonnage calculations.



- (6) The gross tonnage of a drydock having wingwalls that are part of the buoyant hull envelope is calculated assuming the depth includes the height of the wingwalls and applying a shape coefficient of 0.84 as follows:

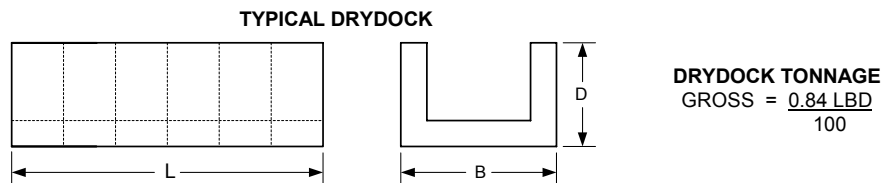

(b) NET TONNAGE

(1) For a vessel having propelling machinery in its hull –

(i) The net tonnage is 90 percent of its gross tonnage, if it is a vessel designed for sailing; or

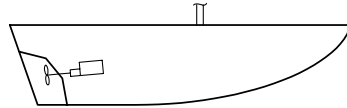

**SAILING HULLS
(PROPELLING MACHINERY IN
HULL)
NET = 0.9 GROSS**

(ii) The net tonnage is 80 percent of its gross tonnage, if it is not designed for sailing.

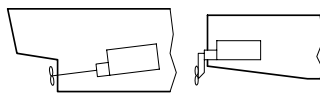

**SHIP-SHAPED, PONTOON AND
BARGE HULLS
(PROPELLING MACHINERY IN
HULL)
NET = 0.8 GROSS**

(2) For a vessel having no propelling machinery in its hull, the net tonnage is the same as its gross tonnage.

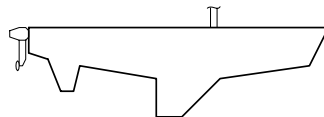

**SAILING HULLS
(NO PROPELLING MACHINERY IN
HULL)
NET = GROSS**

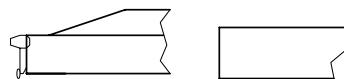

**SHIP-SHAPED, PONTOON AND
BARGE HULLS
(NO PROPELLING MACHINERY
IN HULL)
NET = GROSS**

(c) TONNAGE OF NOVEL CRAFT

The determination of tonnage for novel craft should be referred to the USCG Marine Safety Center. Examples of novel craft are Wing-in-Ground (WIG), SLICE and Small Waterplane Twin Hull (SWATH) craft.

APPENDICES



(Page intentionally left blank)

APPENDIX A

GRANDFATHERING PROVISIONS

A.1 PURPOSE

The purpose of this Appendix is to authorize specific circumstances under which interpretations of the tonnage regulations may be applied that predate the interpretations promulgated by changes to this MTN.

A.2 DISCUSSION

This MTN is intended to provide sufficient interpretive information to enable correct and consistent application of the tonnage measurement regulations. While the MSC's goal is to ensure the interpretive information is clear and keeps pace with the evolution of vessel designs, the MSC recognizes that designers and measurement organizations may apply reasonable interpretations of the regulations that are subsequently superseded by changes to the MTN. The MSC's position is that once tonnages have been certified using reasonable interpretations of the regulations, it is not necessary to remeasure a vessel for the purpose of applying later interpretations, unless requested by the vessel's owner. Further, in order to provide relief to owners who are having vessels designed or redesigned on the basis of interpretations that are subsequently superseded, the MSC considers that grandfathering should be extended to such vessels, and to identical sister vessels.

A.3 GRANDFATHERING AUTHORIZATION

Interpretations of the tonnage regulations that immediately predate the interpretations promulgated by a change to this MTN may be applied at the option of the vessel's owner, for vessels in any of the following three categories:

- (a) A vessel for which tonnages have not been certified and which was contracted for on or before the date of the MTN change.
- (b) A vessel for which tonnages have been certified, but which has undergone modifications that were contracted for on or before the date of the MTN change.
- (c) A sister vessel that is identical from the standpoint of tonnage measurement to a vessel described in either Section A.3(a) or Section A.3(b) above.

A vessel for which tonnages have already been certified should not be remeasured for the purpose of applying the latest interpretations of this MTN, except upon request by the vessel's owner and at the owner's expense.

A.4 CONSIDERATION OF OTHER VESSELS

The MSC recognizes that there may be unique circumstances under which grandfathering should be extended to vessels other than those described in Section A.3 above. The MSC will give consideration to requests to extend grandfathering to other vessels. Such requests must be made in writing to the Commanding Officer, MSC, and must be accompanied by information detailing the specific stage of design and/or construction of the vessel on the date of the MTN change that promulgated the superseded interpretations.

(Page intentionally left blank)

APPENDIX B

DISCUSSION OF CHANGES

SUBPART B - CONVENTION MEASUREMENT

Section 69.63 - Net Tonnage A statement was added authorizing vessel owners/agents to attest to the number of passengers to be carried, in the event that a Ship's Passenger Certificate (or equivalent) has not been issued or will not be issued. In the former case, this change is needed to help avoid unnecessary delays in issuing tonnage certificates in those situations where vessel construction is complete, but appropriate passenger certification documents have not yet been issued.

Section 69.65(d) - Termination of Measurements This section was clarified to reflect that framing of deck structures is ignored when calculating volumes.

Section 69.65(h)(4) - Unenclosed Machinery The list of examples of unenclosed machinery was revised to include movable lift boat support legs.

SUBPART C - STANDARD MEASUREMENT

1. **Section 69.109(q)(7) - Adjusting Breadth Measurements** The figure for this section, which was inadvertently deleted in Change 5 due to an editing error, has been reinstated.

2. **Section 69.117(d)(1) - General** This section was revised to clarify that if a structure is divided into compartments, only those compartments which are open to weather may be exempted as open space. The section was also clarified to highlight that there are no provisions of the regulations that permit open space to progress from one structure to another (e.g., a break to a sunken forecastle), or vertically through openings within a structure. The restriction on progression of open space vertically was described in decision letters dated 6/1/1984, 7/28/1998 and 2/2/2001. Progression of open space to a sunken forecastle within the same structure was provided for in a decision letter dated 5/19/1989.

3. **Section 69.117(d)(2) - End Openings** This section was revised to clarify that a combination of two 3' X 4' openings is required to open the associated space to weather, and that only interior compartments to which open space progresses may be exempted as open space. In addition, a clarification was added to reflect that the coaming height restriction applies to the deck outside the opening rather than the deck inside the opening, based on a decision letter dated 5/19/1989, which described practice allowing progression of open space to a continuation of the compartment below the level of the opening. This is also consistent with the underlying premise of the regulations that a coaming offers protection from the sea and weather. Finally, a restriction was added to preclude progression of space inside the end compartment if the compartment deck height increases by more than 2 feet. This is based on Treasury Decision 53088 dated 8/28/1952, and decision letters dated 2/10/1956, 11/25/1964 and 7/24/1968. A decision letter dated 3/13/1947, which concluded that shell plating does not constitute a coaming, is superseded.

4. **Section 69.117(d)(2)(i) - Two 3' X 4' Tonnage Openings** This section was revised to clarify that circulation of open space through both openings is required, based on decision letters dated 1/14/1948, 11/24/1948, 3/13/1956, 4/16/1963, 2/12/1968, 5/14/1969, 7/20/1970, 8/31/1979 and 6/6/1984.

5. **Section 69.117(d)(2')** - **Additional Requirements for End Openings** This new section was added to provide additional requirements for end openings, as follows:

- a. **Section 69.117(d)(2')(i) - In the Clear Requirements** The words "in the clear" of Section 69.117(d)(2) were interpreted to mean that the opening must be unobstructed for a distance of 30 inches inside and outside of the opening (including "open" structures like ladders), based on decision letters dated 9/11/1964, 4/26/1966, 7/23/1987, 3/27/1992 and 1/24/2003, and an appeal letter from OCMI, New Orleans dated 9/25/1979. This allows for obstructions that are less than two feet in height, based on decision letters dated 10/18/1978 and 6/1/1979. The 30 inch criteria supercedes the 3 foot criteria of decision letters dated 5/1/1972, 12/2/1974, 10/18/1978, 8/31/1979, 10/28/1979 and 6/1/1984. Criteria were also added for evaluating whether obstructions of a temporary nature (other than authorized cover plates or boards) are considered to close the opening. These criteria permit obstructions of a temporary nature whose movement to another location in the vessel would not adversely impact the safe operation of the vessel. Deck cargo is also not considered to close the opening. The criteria are generally less restrictive than a variety of other criteria used in the past, including whether or not the item was "attached to the bulkhead" (decision letters dated 9/16/1964 and 9/22/1964), "stationary" (decision letter dated 10/31/1968), "semi-portable" (decision letter dated 5/1/1972), "fastened" in place (decision letters dated 10/18/1978 and 10/28/1979), "permanently installed" (decision letter dated 3/1/1994), or merely could be considered as an appurtenance (decision letter dated 8/31/1979). Decision letters dated 1/28/1963, 2/14/1964, 9/11/1964, 1/26/1965, 8/20/1965, 9/30/1965 and 7/3/1968, which precluded obstructions of any kind, are superseded. Finally, a decision letter dated 6/1/1984, which required that there be a "full height clear deck access" on either side of the tonnage opening, is superseded. Rather, only the space directly in way of the opening need be in the clear.
- b. **Section 69.117(d)(2')(ii) - Minimum Opening Dimensions** A clarification was added to reflect that the minimum width and height dimensions of the opening be maintained throughout the entire opening, based on decision letters dated 3/2/1929, 12/11/1945, 6/2/1947, 4/23/1951, 5/25/1964 and 11/25/1964. This supersedes a decision letter dated 9/30/1920, allowing rounded corners to infringe upon the clear opening requirement.
- c. **Section 69.117(d)(2')(iii) - Progression of Open Space Within the Structure** Requirements were included on progression of open space throughout a compartment having an exterior bulkhead opening or openings. Once a compartment is considered open, the entire compartment is eligible for exemption as open space, regardless of whether or not appurtenances or other obstructions within the compartment interfere with the progression of open space throughout the compartment. In the clear requirements for interior bulkhead openings continue to apply. This approach is consistent with that of decision letters dated 6/19/1947, 1/14/1948, 7/3/1961 and 5/25/1964, and the 1989 changes to the tonnage regulations which provided for exemption of open space through the use of openings in interior bulkheads of compartments. Other approaches described in decision letters 11/6/1953, 2/10/1956, 3/13/1956, 1/24/1959, 4/26/1966, 5/29/1967, 7/24/1968, 10/31/1968 (two letters), 5/2/1969, 8/11/1976, 8/31/1979, 8/28/1980, 6/1/1984, 4/20/1987, 7/14/1987, 3/1/1994, 7/21/1997, 7/28/1998 and 1/24/2003 are superseded, most of which involved establishing an unobstructed "progression path" from an associated exterior bulkhead opening.
- d. **Section 69.117(d)(2')(iv) - Angled or Curved Bulkheads** Criteria were added for evaluating openings in curved or sloped end bulkheads. Specifically, a 45 degree criterion was established for use in evaluating when a sloped or angled bulkhead constitutes an end or side bulkhead. Also, the projected area was specified for use in applying minimum size requirements. The 45 degree criterion has been authorized under a variety of circumstances to define the point of transition between the sides and ends of structures (e.g., decision letters dated 6/19/1980, 6/23/1980, and 1/15/1986).

e. **Section 69.117(d)(2')(v) - Deck or Platform on Exterior Side of Opening** This new section was added to clarify that a permanent deck or platform must be installed on the exterior side of an end bulkhead opening within a distance of 2 feet below the opening, based on decision letters dated 10/29/1964, 10/30/1970, 4/15/1971, 8/31/1979, 6/1/1984, 9/24/1987, 6/9/1988, 3/27/1992 and 6/2/1997. This requirement is ultimately derived from the 2 foot coaming height requirement (which is not applicable to side openings), notwithstanding decision letters that referred to "access" to tonnage openings (including letters dated 10/29/1964, 5/1/1972, 12/2/1974, 6/1/1984, 9/24/1987, and 6/2/1997). Either gratings or solid decking are allowed, consistent with past practice.

6. **Section 69.117(d)(3) - Open Space Progression to Interior Compartments** This section was revised to include the 2' deck height restriction of Section 69.117(d)(2), and to add a number of requirements, as follows:

a. **Section 69.117(d)(3)(i) - Establishing Compartment Boundaries** The term "compartment" was defined to be a portion of a larger space sectioned off in some manner by bulkheads. As provided for in decision letters dated 6/5/1956, 5/25/1964, 4/26/1966, 10/31/1968 and 8/31/1979, treatment of open passageways and dead-ended spaces as part of the same open compartment (until such point that the passageway or dead-ended space increases in height or width) was authorized. Finally, use of a "projected" boundary was authorized for situations where one boundary of the compartment is not clearly defined, such as situations involving corners.

b. **Section 69.117(d)(3)(ii) - Progression of Open Space From Other Interior Compartments** General requirements for progression of open space from one interior compartment (or series of compartments) to another were included, as follows:

- (1) Opening Locations A statement was added clarifying that open space can progression through tonnage openings installed in longitudinal, as well as transverse bulkheads, based on decision letters dated 11/24/1948, 1/28/1963, 10/31/1968 and 8/31/1979.
- (2) Circulation Requirement For emphasis, the circulation requirement of Section 69.117(d)(2)(i) were referenced.
- (3) Obstructions to Interior Bulkhead Openings For emphasis, the in the clear requirements of Section 69.117(2')(i) were referenced.
- (4) Obstructions for Openings Where Boundary Not Clearly Defined Requirements were included on how to establish the location of an opening in a interior bulkhead of a compartment for those situations where the bulkhead is not well defined. The approach used is generally consistent with that authorized by the decision letters dated 5/25/1964 and 8/31/1979, although the approach of this new section ignores obstructions that are more 30 inches from the "opening".
- (5) Temporary Covers for Openings A clarification was added that temporary covers for openings in interior bulkheads must be installed on the side of the bulkhead toward the associated end bulkhead, based on decision letters dated 9/24/1987 and 2/17/1995, and Figure 12 of 46 CFR 69.123. A clarification was included to reflect that the cover may be installed on either side of the opening for situations where there is "circulation".
- (6) Propelling Machinery Space Bulkheads A statement was added to reflect that there is no longer a prohibition against progression of open space through a propelling machinery space bulkhead, consistent with decision letters dated 8/6/1976 and 9/4/1996. The prohibition, addressed in

decision letters dated 4/11/1967, 10/30/1967, 2/12/1968, 8/31/1979 and 11/20/1980, was an attempt to prevent an unsafe downflooding situation in certain scenarios, and was unrelated to requirements of the tonnage regulations, or the underlying statute. However, a note was added to highlight the potential safety impact of such openings.

- c. **Section 69.117(d)(3)(iii) - Treatment of Bars and Similar Subspaces** A provision for allowing progression of open space behind counters that meet certain minimum requirements was included, based on decision letters dated 2/17/1995 and 6/15/1995 (two letters). This supersedes the prohibition against progression of open space behind a permanent counter of a decision letter dated 8/31/1979.
7. **Section 69.117(d)(4) - Shifting Boards in Channel Sections** This section was revised to clarify that anything that seals the shifting boards will render the opening as closed.
8. **Section 69.117(d)(5) - Plates/Boards with Hook Bolts** This section was revised to incorporate changes similar to the changes made to Section 69.117(d)(4), and to reflect that the cover plates or boards must fay against the exterior surface of the bulkhead. This latter requirement is based on decision letters dated 9/27/1987 and 2/17/1995, and Figure 12 of 46 CFR 69.123.
9. **Section 69.117(d)(6) - Plates/Boards with Bolts and Crosspieces** This section was revised to incorporate changes similar to the changes made to Section 69.117(d)(5). It also includes the clarification that there is nothing to preclude use of a single plate as a crosspiece in a "sandwich" configuration, consistent with the discussion in the Federal Register of August 31, 1999 (64 FR 47402) and decision letters dated 3/8/1979 and 9/25/2001. Finally, a statement was included to reflect that, unlike the temporary cover configuration involving hook bolts, there are no bolt spacing requirements for this configuration.
10. **Section 69.117(d)(6') - Additional Requirements for Tonnage Opening Covers** This new section was added to provide additional requirements for tonnage opening covers, as follows:
- a. **Section 69.117(d)(6')(i) - Cover Plates and Boards** A clarification was added that a cover plate or board must be a single entity, although it can be composed of different elements and materials. This is based on decision letters dated 4/1/1941, 3/24/1946, 6/3/1946, 1/5/1949, 12/16/1980 and 4/15/1982. A second clarification was added to highlight the acceptability of "plug type" closures that fully meet all requirements of Section 69.117(d)(5) or (6), based on decision letters dated 12/16/80, 4/15/1982 and 11/26/1997. Earlier "plug" configurations that were disallowed by decision letters dated 1/7/1958 and 12/11/1969 apparently were not fitted with a lip to fay against the bulkhead, thereby rendering the opening closed.
- b. **Section 69.117(d)(6')(ii) - Attachments and Penetrations** A clarification was added that a cover plate or board may be fitted with attachments or penetrations, provided they do not render the opening other than non-tight. This is based on decision letters dated 9/13/1950, 11/22/1950, 8/29/1952, 4/24/1956, 12/10/1965, 4/11/1967, 8/6/1969, 8/31/1979, 6/1/1984 and 8/29/1988.
- c. **Section 69.117(d)(6')(iii) - Cover Fasteners** A requirement was added that a cover must "fall free" if the fasteners holding it in place are removed, and that the fasteners must be accessible at all times. The latter requirement is based on a decision letter dated 12/19/1969. Temporary covers for securing devices are allowed, consistent with past practice.
- d. **Section 69.117(d)(6')(iv) - Alternate Covers** A clarification was added that wire mesh or a fabric-like material such as canvas may be applied over an otherwise uncovered opening without rendering the open closed. This is based on the requirements of 46 CFR 69.117(d)(2), which provides for wire

mesh screen or canvas to be secured over certain end openings, and decision letters dated 12/30/1915, 5/17/1940, 1/27/1941, 11/4/1941, 12/16/1946, 11/21/1947, 5/14/1948, 1/18/1949, 7/5/1949, 7/3/1950, 8/15/1950, 4/24/1956 and 5/20/1964. A statement was included to highlight that doors and similar items cannot be used as a temporary cover, based on decision letters dated 6/1/1984, 2/25/1986 and 8/29/1988. A decision letter dated 10/7/1947, which authorized a cover plate fitted to a roller track, is superseded.

- e. **Section 69.117(d)(6')(v) - Impact on Vessel Safety** A discussion was included on safety aspects of openings, including watertightness and fire protection.

11. **Section 69.117(d)(7) - Structures Entirely Open From Aft End** This section was revised to clarify that open space may progress from a structure entirely open at the aft end to another compartment, provided minimum requirements for progression from other end openings are met. Also, flexibility was added to allow use of fabric-like material in addition to canvas to temporarily cover the opening, to reflect increasing use in the maritime industry of alternate materials.

12. **Section 69.117(d)(8) - Opposite Side Openings** This new section was added to provide the option of using opposite side openings as a means of exempting open space within an enclosed structure. This option explicitly appeared in the tonnage regulations prior to the 1989, but currently appears only implicitly within item (d) of the definition of "uppermost complete deck" in 46 CFR 69.103. Decision letters dated 2/4/1994 and 7/20/2000 authorized the use of opposite side openings. Specific criteria for side openings, which stem from Treasury Decision 51384 dated January 2, 1946, are included as follows:

- a. **Section 69.117(d)(8)(i) - Openings are Opposite** A requirement was included that the openings must be directly across from each other, as reflected in decision letters dated 7/11/1930, 8/25/1930, 7/20/1964, 12/2/1965, 8/31/1979, 4/20/1987 and 7/20/2000, and not separated by a bulkhead, as reflected in a decision letter dated 9/24/1987. Decision letters dated 11/24/1948 and 6/1/1984, which provided for progression of open space through openings in bulkheads between opposite side openings, are superseded.
- b. **Section 69.117(d)(8)(ii) - Opening Size** The specific opening size criteria of Treasury Decision 51384 were included. The criteria were clarified to reflect that for full length side openings, the "required height" of Treasury Decision 51384 refers to either a 3 foot height or the full height of the space, whichever is less. This permits the exemption of space between opposite side openings in the case where the sides of a structure are completely open, even though the height of the structure is less than 3 feet. This section also provides for using stanchions to separate a series of side openings, based on a decision letter dated 9/24/1987, and for taking into account rounded edges when minimum height restrictions apply, based on a decision letter dated 4/19/1948.
- c. **Section 69.117(d)(8)(iii) - Coamings** This new section was added to clarify that coaming height restrictions that apply to end openings do not apply to side openings, based on decision letters dated 7/20/1964 and 10/22/1980, although they do apply in the case of progression of open space within the structure. Presumably, the greater exposure of side openings to the weather obviates the need for a coaming height restriction. However, for space that has progressed inside the vessel, coaming height restrictions have consistently been applied.
- d. **Section 69.117(d)(8)(iv) - Progression of Open Space** This new section was added to reflect that open space may progress from space opened by opposite side openings, based on decision letters dated 12/14/1945, 11/24/1948 (two letters), 12/20/1948, and 6/1/1984. The prohibition of the decision letter dated 8/31/1979 against progression of open space from certain side openings appears to have no basis in the regulations, or earlier decision letters, and is superseded.

13. **Section 69.117(e)(5) - Coamings and Covers** This section was revised to clarify that sealing a temporary cover on a middle line opening will cause the opening to be considered as closed. While an explicit prohibition against sealing of middle line openings has not been included in the regulations since 1938, allowing such openings to be sealed is contrary to the underlying premise of the regulations upon which a shelter deck space can be exempted as open space by means of such an opening. This is reflected in an Executive Order dated April 1, 1942, which allowed making middle line openings to be made watertight during World War II.

14. **Section 69.117(g)(3) - Under-Deck** A procedure was added to ensure that under-deck water ballast space exemptions reflect only those portions of water ballast spaces that were included in the under-deck volume calculations, and not the portions that are outside of the line of the ordinary frames. This procedure combines elements of procedures formerly used by OCMI, Mobile and OCMI, New Orleans.